

# **USER'S MANUAL**

**POS-3520**

**15" POS Terminal**

**With Intel® Atom® D525**

**Platform**

**POS-3520**

**M2**

# ***POS-3520 POS System*** ***With LCD / Touchscreen***

## ***OPERATION MANUAL***

### **COPYRIGHT NOTICE**

This operation manual is meant to assist users in installing and setting up the system. The information contained in this document is subject to change without prior any notice.

This manual is copyrighted May 2011. (Revised Edition: June 2011)  
You may not reproduce or transmit in any form or by any means, electronic, or mechanical, including photocopying and recording.

### **ACKNOWLEDGEMENTS**

All trademarks and registered trademarks mentioned herein are the property of their respective owners.

### **CE NOTICE**

This is a class A product. In a domestic environment this product may cause radio interference in which case the user may be required to take adequate measures.

---

---

## **FCC NOTICE**

This equipment has been tested and found to comply with the limits for a Class A digital device, pursuant to part 15 of the FCC Rules. These limits are designed to provide reasonable protection against harmful interference when the equipment is operated in a commercial environment. This equipment generates, uses, and can radiate radio frequency energy and, if not installed and used in accordance with the instruction manual, may cause harmful interference to radio communications. Operation of this equipment in a residential area is likely to cause harmful interference in which case the user will be required to correct the interference at his own expense.

You are cautioned that any change or modifications to the equipment not expressly approve by the party responsible for compliance could void your authority to operate such equipment.

**CAUTION!** Danger of explosion if battery is incorrectly replaced. Replace only with the same or equivalent type recommended by the manufacturer. Dispose of used batteries according to the manufacturer's instructions.

**WARNING!** Some internal parts of the system may have high electrical voltage. And therefore we strongly recommend that qualified engineers can open and disassemble the system.

The LCD and Touchscreen are easily breakable, please handle them with extra care.

---

---

## TABLE OF CONTENTS

### CHAPTER 1 INTRODUCTION

1-1	About This Manual .....	1-2
1-2	POS Illustration .....	1-3
1-3	System Specification .....	1-4
1-4	Safety Precautions .....	1-6

### CHAPTER 2 SYSTEM CONFIGURATION

2-1	Jumper & Connector Quick Reference Table .....	2-2
2-2	Component Locations .....	2-3
2-3	How to Set the Jumpers .....	2-4
2-4	COM Port & VGA Connector .....	2-6
2-5	COM Port RI and Voltage Selection .....	2-9
2-6	Mini-DIN and USB Connector .....	2-13
2-7	LAN & USB Connector .....	2-14
2-8	Cash Drawer Connector .....	2-15
2-9	Cash Drawer Power Selection .....	2-16
2-10	Power LED Connector .....	2-17
2-11	Smart FAN Connector .....	2-17
2-12	Power Connector .....	2-17
2-13	Reset Switch Connector .....	2-18
2-14	Power for Thermal Printer Connector .....	2-18
2-15	External Speaker Connector .....	2-18
2-16	Inverter Connector .....	2-19
2-17	MSR/ Card Reader Connector .....	2-20
2-18	Printer Connector .....	2-20
2-19	LVDS Connector .....	2-21
2-20	SATA Connector .....	2-23
2-21	SATA Power Connector .....	2-23
2-22	Touch Panel Connector .....	2-24
2-23	Touch Panel Selection .....	2-24
2-24	Touch Panel Interface Type Selection .....	2-25
2-25	Clear CMOS Data Selection .....	2-26
2-26	Compact Flash Connector .....	2-27

---

---

**CHAPTER 3 SOFTWARE UTILITIES**

3-1	Introduction .....	3-2
3-2	Intel® Chipset Software Installation Utility .....	3-3
3-3	VGA Driver Utility .....	3-4
3-4	LAN Driver Utility .....	3-5
3-5	Sound Driver Utility .....	3-6
3-6	Touch Screen Driver Utility .....	3-7
3-7	OS Support Table .....	3-8

**CHAPTER 4 AMI BIOS SETUP**

4-1	Introduction .....	4-2
4-2	Entering Setup .....	4-3
4-3	Main .....	4-5
4-4	Advanced .....	4-6
4-5	Boot .....	4-16
4-6	Security Settings .....	4-20
4-7	Chipset .....	4-21
4-8	Exit .....	4-25

**APPENDIX A SYSTEM ASSEMBLY**

	Exploded Diagram for 2 Inch Thermal Printer Remove/ Install	A-2
	Exploded Diagram for 3 Inch Thermal Printer Remove/ Install	A-5
	Exploded Diagram for MSR & Fingerprint Module Remove/ Install .....	A-8
	Exploded Diagram for Fingerprint Module .....	A-9
	Exploded Diagram for POS-3520 Hard Disk Drive Remove/ Install .....	A-11
	Exploded Diagram for POS-3520 LCD Panel Remove/ Install ..	A-14
	Exploded Diagram for POS-3520 Mini-PCIE Installation ....	A-16
	Exploded Diagram for POS-3520 Motherboard .....	A-17
	Exploded Diagram for POS-3520 MSR Module .....	A-19
	Exploded Diagram for POS-3520 MSR & LCD Assembly ...	A-21
	Exploded Diagram for POS-3520 Printer Assembly .....	A-22
	Exploded Diagram for POS-3520 Top Cover Assembly .....	A-24
	Exploded Diagram for POS-3520 VFD Module Assembly ....	A-25

---

---

**APPENDIX B TECHNICAL SUMMARY**

Block Diagram .....	B-2
Interrupt Map .....	B-3
DMA Channels Map .....	B-4
I/O Map .....	B-4
Watchdog Timer Configuration .....	B-7
Flash BIOS Update .....	B-9



# ***INTRODUCTION***

CHAPTER

***1***

This chapter gives you the information for POS-3520. It also outlines the System specifications.

Section includes:

- About This Manual
- System Specifications
- Safety precautions

**Experienced users can skip to chapter 2 on page 2-1 for a Quick Start.**

## **1-1. ABOUT THIS MANUAL**

Thank you for purchasing our POS-3520 System. The POS-3520 is an updated system designed to be comparable with the highest performance of IBM AT personal computers. The POS-3520 provides faster processing speed, greater expandability and can handle more tasks than before. This manual is designed to assist you how to install and set up the whole system. It contains four chapters. The user can apply this manual for configuration according to the following chapters:

### ***Chapter 1 Introduction***

This chapter introduces you to the background of this manual. It also includes illustration and the specification for the whole system. The final page of this chapter indicates some safety reminders on how to take care of your system.

### ***Chapter 2 Hardware Configuration***

This chapter outlines the Prox3520LF component's location and their function. In the end of this chapter, you will learn how to set jumper and how to configure this card to meet your own needs.

### ***Chapter 3 Software Utilities***

This chapter contains helpful information for proper installations of the Intel Utility, VGA Utility, LAN Utility, Sound Utility, Touch Screen Utility and Flash BIOS Update. It also describes the Wireless Utility.

### ***Chapter 4 AMI BIOS Setup***

This chapter indicates you how to set up the BIOS configurations.

### ***Appendix A System Assembly***

This section gives you the exploded diagram for the whole system unit.

### ***Appendix B Technical Summary***

This section gives you the information about the Technical maps.



1-2. POS SYSTEM ILLUSTRATION

Front View

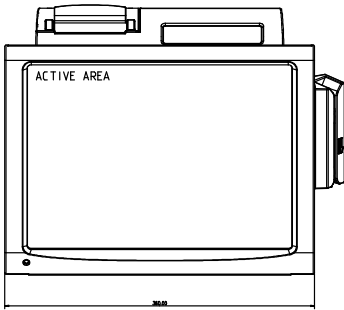

Rear View

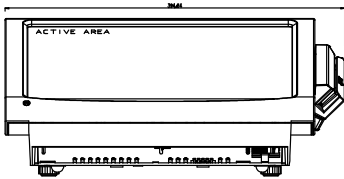

Side View

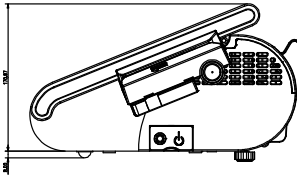
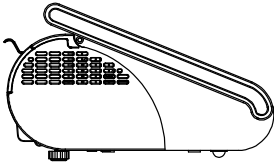

Bottom View

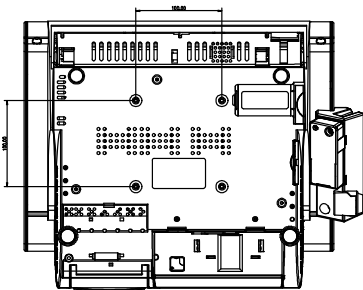

Quarter View

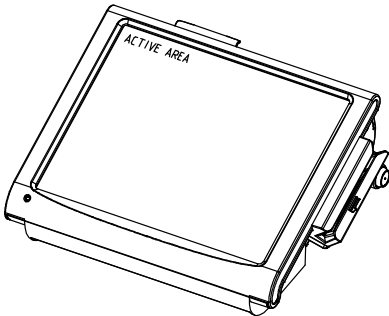

## **1-3. SYSTEM SPECIFICATIONS**

### **MAINBOARD (PROX3520LF)**

- **CPU TYPE :**  
Intel® ATOM™ Pineview D525
- **CHIPSET :**  
Intel® ICH8M
- **MEMORY :**  
2 x DDR3 SO-DIMM Slot, 1G DDR3 SO-DIMM default (up to 4GB)
- **CACHE :**  
Depended on CPU
- **REAL-TIME CLOCK / CALENDAR :**  
Embedded in Intel® ICH8M South Bridge
- **BIOS :**  
AMI BIOS
- **KEYBOARD CONNECTOR :**  
PS/2 Keyboard, with mini DIN connector on rear panel.
- **MOUSE CONNECTOR :**  
PS/2 Mouse, with mini DIN connector on rear panel.
- **SERIAL PORT :**  
3 x DB-9 & 1 x RJ45, +5V/ 12V selectable
- **UNIVERSAL SERIAL BUS PORT :**  
5 x USB ports
- **LAN FUNCTION :**  
1 x 10/100/1000 Mbps
- **AUDIO FUNCTION :**  
1 x 2W Speaker

● **VGA FUNCTION :**

1 x DB-15 VGA interface

● **DIMENSION (WxHxD):**

356 x 309 x 167 mm (14.02" x 12.17" x 6.57")

● **System Weight:**

5.7 kg

● **LCD PANEL:**

<b>Type</b>	SVGA
Max. Resolution	1024 x 768
Size/Type	15" / TFT
Viewing Angel (degree)	24~30 degrees
Brightness	250 cd / m <sup>2</sup>
Signal Interface (bit)	TTL (18-bit)

● **TOUCH PANEL :**

15" 5wire Analog resistive.

● **PRINTER :**

2" or 3" easy loading thermal printer with Auto cutter  
(\* Diameter of paper roll can not exceed 8 cm.)

● **I-BUTTON : (OPTIONAL)**

Read only, output through PS/2 KB interface

● **MSR : (OPTIONAL)**

JIS-I or II, ISO Tracker 1+2+3 (PS/2 KB Interface)

● **Wireless LAN : (OPTIONAL)**

Mini PCIe Wireless LAN Module (802.11b/g)

● **FINGERPRINT : (OPTIONAL)**

Embedded Fingerprint module (USB interface)

## **1-4. SAFETY PRECAUTIONS**

Following messages are safety reminders on how to protect your systems from damages. And thus, helps you lengthen the life cycle of the system.

### **1. Check the Line Voltage**

- a. The operating voltage for the power supply should cover the range of 100VAC-240VAC, otherwise the system may be damaged.

### **2. Environmental Conditions**

- a. Place your POS-3520 on a sturdy, level surface. Be sure to allow enough room on each side to have easy access.
- b. Avoid extremely hot or cold places to install your POS-3520 POS Terminal.
- c. Avoid exposure to sunlight for a long period of time (for example in a closed car in summer time. Also avoid the system from any heating device.). Or do not use POS-3520 when it's been left outdoors in a cold winter day.
- d. Bear in mind that the operating ambient temperature is from 0°C up to +35°C.
- e. Avoid moving the system rapidly from a hot place to a cold place or vice versa because condensation may come from inside of the system.
- f. Place POS-3520 against strong vibrations, which may cause hard disk failure.
- g. Do not place the system too close to any radio active device. Radio-active device may cause interference.
- h. Always shutdown the operation system before turning off the power.

### **3. Handling**

- a. Avoid putting heavy objects on top of the system.

### **4. Good Care**

- a. When the outside of the case is stained, remove the stain with neutral washing agent with a dry cloth.
- b. Never use strong agents such as benzene and thinner to clean the system.
- c. If heavy stains are present, moisten a cloth with diluted neutral washing agent or with alcohol and then wipe thoroughly with a dry cloth.
- d. If dust has been accumulated on the outside, remove it by using a special made vacuum cleaner for computers.

# ***SYSTEM CONFIGURATION***

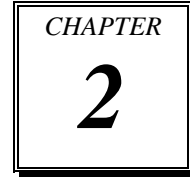

Helpful information that describes the jumper & connector settings, and component locations.

Section includes:

- Jumper & Connector Quick Reference Table
- Component Locations
- Configuration and Jumper settings
- Connector Pin Assignments

**2-1. JUMPER & CONNECTOR QUICK REFERENCE TABLE**

<b>Connector &amp; Jumper</b>	<b>Name</b>	<b>Page</b>
COM Port & VGA Connector	COM1, COM3, COM4, COM2-1, JVGACOM2	2-6
COM Port RI and Voltage Selection	JP_COM1, JP_COM2, JP_COM3, JP_COM4	2-9
MINI-DIN and USB Connector	JPS2USB1, USB5, USB6	2-13
LAN & USB Connector	JRJ45USB1	2-14
Cash Drawer Connector	DRW1, DRW2	2-15
Cash Drawer Power Selection	JP14, JP17	2-16
Power LED Connector	LED-1	2-17
Smart Fan Connector	FAN2	2-17
Power Connector	FAN1	2-17
Reset Switch Connector	JRST1	2-18
Power for Thermal printer Connector	PRT_PWR1	2-18
External Speaker Connector	SPK1	2-18
Inverter Connector	INV1, INV2	2-19
MSR/ Card Reader Connector	PS2	2-20
Printer Connector	LPT1	2-20
LVDS Connector	LVDS1, LVDS2	2-21
SATA Connector	SATA1	2-23
SATA Power Connector	JPWR_4P1	2-23
Touch Panel Connector	TOUCH1	2-24
Touch Panel Selection	JP16	2-24
Touch Panel Interface Type Selection	JP15	2-25
Clear CMOS Data Selection	JP1	2-26
Compact Flash Connector	CF1	2-27

## 2-2. COMPONENT LOCATIONS

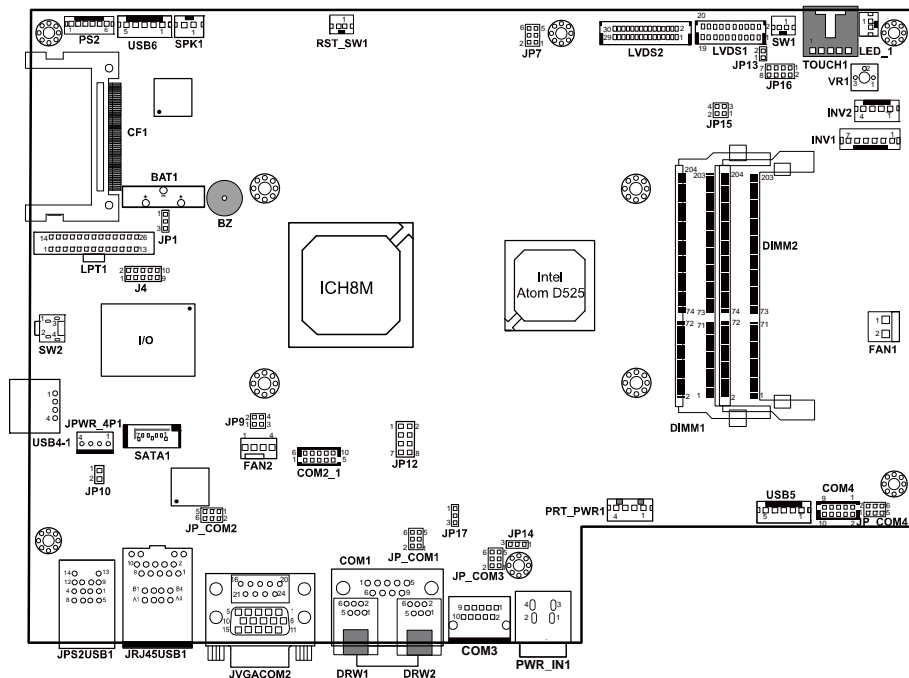

POS-3520 Connector, Jumper and Component locations

## **2-3. HOW TO SET THE JUMPERS**

You can configure your board by setting the jumpers. Jumper is consists of two or three metal pins with a plastic base mounted on the card, and by using a small plastic "cap", Also known as the jumper cap (with a metal contact inside), you are able to connect the pins. So you can set-up your hardware configuration by "opening" or "closing" pins.

The jumper can be combined into sets that called jumper blocks. When the jumpers are all in the block, you have to put them together to set up the hardware configuration. The figure below shows how this looks like.

### **JUMPERS AND CAPS**

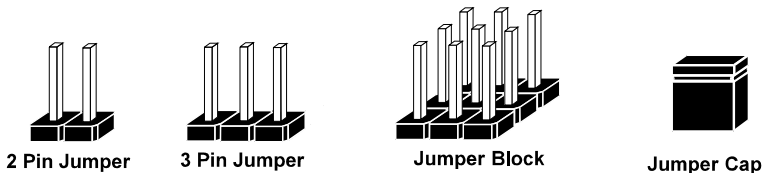

If a jumper has three pins for example, labelled PIN1, PIN2, and PIN3. You can connect PIN1 & PIN2 to create one setting and shorting. You can either connect PIN2 & PIN3 to create another setting. The same jumper diagrams are applied all through this manual. The figure below shows what the manual diagrams look and what they represent.



### JUMPER DIAGRAMS



Jumper Cap looks like this

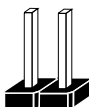

2 pin Jumper looks like this

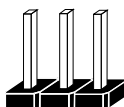

3 pin Jumper looks like this

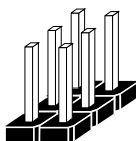
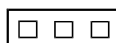

Jumper Block looks like this

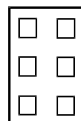

### JUMPER SETTINGS



2 pin Jumper closed(enabled)  
looks like this

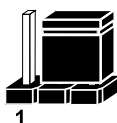

3 pin Jumper  
2-3 pin closed(enabled)  
looks like this



Jumper Block  
1-2 pin closed(enabled)  
looks like this

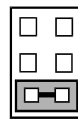

## 2-4. COM PORT & VGA CONNECTOR

There are four COM ports enhanced in this board namely: COM1, COM2, COM3 and COM4.

### COM1: COM1 Connector

The COM1 Connector assignments are as follows:

PIN	ASSIGNMENT
1	DCD2
2	RXD2
3	TXD2
4	DTR2
5	GND
6	DSR2
7	RTS2
8	CTS2
9	RI / +5V / +12V selectable

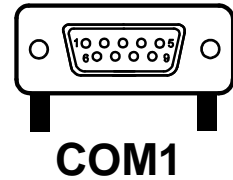

### COM3: COM3 Connector

The pin assignments are as follows:

PIN	ASSIGNMENT
1	DCD3
2	RXD3
3	TXD3
4	DTR3
5	GND
6	DSR3
7	RTS3
8	CTS3
9	RI/+5V/+12 selectable
10	NC

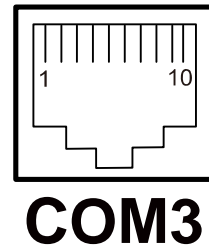

**COM4:** COM4 Connector

The pin assignments are as follows:

PIN	ASSIGNMENT
1	DCD4
2	RXD4
3	TXD4
4	DTR4
5	GND
6	DSR4
7	RTS4
8	CTS4
9	RI
10	NC



**COM2-1:** COM2 External Connector

The pin assignments are as follows:

PIN	ASSIGNMENT
1	DCD1
2	RXD1
3	TXD1
4	DTR1
5	GND
6	DSR1
7	RTS1
8	CTS1
9	RI/+5V/+12 selectable
10	NC



**JVGACOM2: COM2 & VGA Connector**

The COM2 & VGA Connector assignments are as follows:

PIN	ASSIGNMENT
1	RED
2	GREEN
3	BLUE
4	NC
5	GND
6	GND
7	GND
8	GND
9	+5V
10	GND
11	NC
12	DDCA DATA
13	HSYNC
14	VSYNC
15	DDCA CLK
16	DCD1
17	RXD1
18	TXD1
19	DTR1
20	GND
21	DSR1
22	RTS1
23	CTS1
24	RI/+5V/+12 selectable



 All COM port is selectable for RI, +5V or +12V. For more information, please refer to our “COM RI and Voltage Selection”.

## 2-5. COM PORT RI & VOLTAGE SELECTION

### JP\_COM1: COM1 RI & Voltage Selection

The selections are as follows:

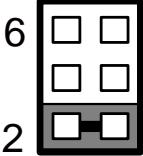
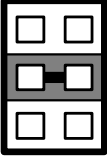
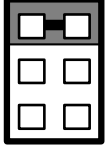
SELECTION	JUMPER SETTINGS	JUMPER ILLUSTRATION
RI	1-2	 <p><b>JP_COM1</b></p>
VCC12	3-4	 <p><b>JP_COM1</b></p>
VCC	5-6	 <p><b>JP_COM1</b></p>

\*\*\*Manufacturing Default – RI.

**JP\_COM2: COM2 RI & Voltage Selection**

The selections are as follows:

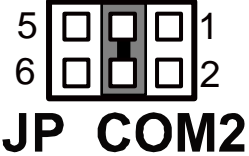
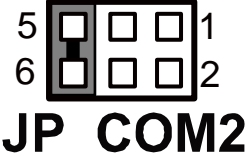
SELECTION	JUMPER SETTINGS	JUMPER ILLUSTRATION
RI	1-2	 5 1 6 2 <b>JP_COM2</b>
VCC12	3-4	 5 1 6 2 <b>JP_COM2</b>
VCC	5-6	 5 1 6 2 <b>JP_COM2</b>

\*\*\*Manufacturing Default – RI.

**JP\_COM3: COM3 RI & Voltage Selection**

The selections are as follows:

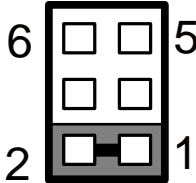
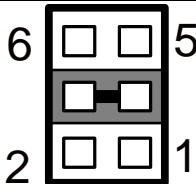
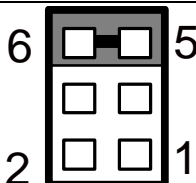
SELECTION	JUMPER SETTINGS	JUMPER ILLUSTRATION
RI	1-2	 <p><b>JP_COM3</b></p>
VCC12	3-4	 <p><b>JP_COM3</b></p>
VCC	5-6	 <p><b>JP_COM3</b></p>

\*\*\*Manufacturing Default – RI.

**JP\_COM4: COM4 RI & Voltage Selection**

The selections are as follows:

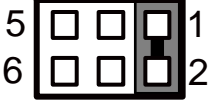
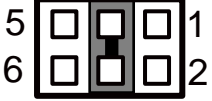
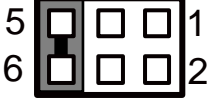
SELECTION	JUMPER SETTINGS	JUMPER ILLUSTRATION
RI	1-2	 <p><b>JP_COM4</b></p>
VCC12	3-4	 <p><b>JP_COM4</b></p>
VCC	5-6	 <p><b>JP_COM4</b></p>

\*\*\*Manufacturing Default – RI.



## 2-6. MINI-DIN AND USB CONNECTOR

**JPS2USB1:** Two USB Ports Connector and MINI-DIM

MINI-DIN connector can support keyboard, Y-cable, or PS/2 Mouse

The pin assignment is as follows:

PIN	ASSIGNMENT
1	GND
2	USB2+
3	USB2-
4	VCC5
5	GND
6	USB3+
7	USB3-
8	VCC5
9	GND
10	KDAT
11	MDAT
12	V5SB
13	KCLK
14	MCLK

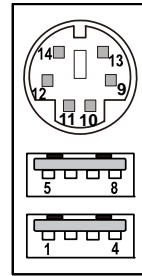

**JPS2USB1**

**USB5:** Internal USB Ports Connector

The pin assignment is as follows:

PIN	ASSIGNMENT
1	USB5-
2	USB5+
3	GND
4	VCC5
5	GND



**USB5**

**USB6: Internal USB Ports Connector**

The pin assignment is as follows:

PIN	ASSIGNMENT
1	USB6-
2	USB6+
3	GND
4	VCC5
5	GND

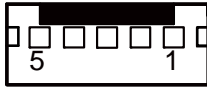

**USB6**

**2-7. LAN & USB CONNECTOR**

**JRJ45USB1: LAN & USB Connector**

The pin assignments are as follows:

PIN	ASSIGNMENT
1	LAN1_MDIP0
2	LAN1_MDIN0
3	LAN1_MDIP1
4	LAN1_MDIN1
5	LAN1_MDIP2
6	LAN1_MDIN2
7	LAN1_MDIP3
8	LAN1_MDIN3

Orange Green

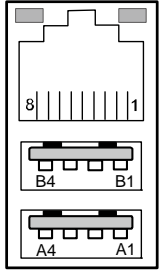

**JRJ45USB1**

PIN	ASSIGNMENT
A1	VCC5
A2	USB0-
A3	USB0+
A4	GND
B1	VCC5
B2	USB1-
B3	USB1+
B4	GND

## 2-8. CASH DRAWER CONNECTOR

**DRW1, DRW2:** Cash Drawer Connector

The pin assignment is as follows:

PIN	ASSIGNMENT
1	GND
2	Drawer Open
3	Drawer Sense
4	+12V
5	NC
6	GND

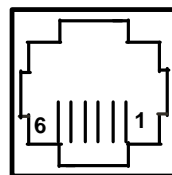

**DRW1**

### **PROX-A3520 cash drawer control in GPIO port**

To Open Drawer1 (GPIO 7)

Write "00" to I/O Port "50C" Bit 7

To Close Drawer1

Write "01" to I/O Port "50C" Bit 7

Detect Drawer1 Status

Read I/O "50E" (GPIO 20)

Definition (bit4)

To Open Drawer2 (GPIO 6)

Write "00" to I/O Port "50C" Bit 6

To Close Drawer2

Write "01" to I/O Port "50C" Bit 6

Detect Drawer2 Status

Read I/O "538" (GPIO 37)

Definition (bit5)

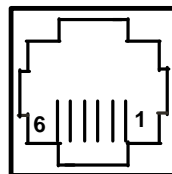





**DRW2**

## 2-9. CASH DRAWER POWER SELECTION

**JP14, JP17:** Cash Drawer Power Selection

The jumper settings are as follows:

SELECTION	JUMPER SETTINGS	JUMPER ILLUSTRATION	
+12V	2-3	 <p><b>JP14</b></p>	 <p><b>JP17</b></p>
+24V (default)	1-2	 <p><b>JP14</b></p>	 <p><b>JP17</b></p>

\*\*\* Manufactory default --- +24V.

## 2-10. POWER LED CONNECTOR

**LED-1:** LED Connector  
The pin assignment is as follows:

PIN	ASSIGNMENT
1	GND
2	VCC_PWR_LED

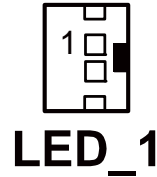

## 2-11. SMART FAN CONNECTOR

**FAN2:** CPU Smart Fan Connector.

The pin assignments are as follows:

PIN	ASSIGNMENT
1	GND
2	12V
3	CPUFANIN
4	CPUFANOUT

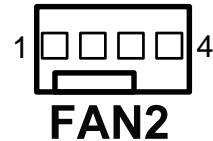

## 2-12. POWER CONNECTOR

**FAN1:** Provide 12 Voltage Connector  
The pin assignment is as follows:

PIN	ASSIGNMENT
1	VCC12
2	GND

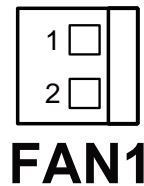

### 2-13. RESET SWITCH CONNECTOR

**RST\_SW1:** Power Switch Connector

The pin assignment is as follows:

PIN	ASSIGNMENT
1	RST_SW
2	GND



**RST\_SW1**

### 2-14. POWER FOR THERMAL PRINTER CONNECTOR

**PRT\_PWR1:** Power for Thermal printer Connector

The pin assignment is as follows:

PIN	ASSIGNMENT
1	VCC24SB
2	VCC24SB
3	GND
4	GND

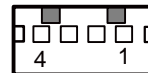

**PRT\_PWR1**

### 2-15. EXTERNAL SPEAKER CONNECTOR

**SPK1:** External Speaker Connector

The pin assignment is as follows:

PIN	ASSIGNMENT
1	SPK_GND
2	SPK_OUT

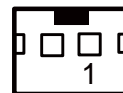

**SPK1**

## 2-16. INVERTER CONNECTOR

### INV1: Inverter Connector

The pin assignment is as follows:

PIN	ASSIGNMENT
1	+12V
2	+12V
3	GND
4	GND
5	LVDS_BKLTEN
6	BRCTR
7	GND



**INV1**

### INV2: Inverter Connector

The pin assignment is as follows:

PIN	ASSIGNMENT
1	+12V
2	GND
3	LVDS_BKLTEN
4	BRCTR



**INV2**

## 2-17. MSR/ CARD READER CONNECTOR

**PS2:** MSR/ Card Reader Connector

The pin assignment is as follows:



**PS2**

PIN	ASSIGNMENT
1	KB_CLK (Output)
2	KB_CLK_C (Input)
3	KB_DATA_C (Input)
4	KB_DATA (Output)
5	+5V
6	GND

## 2-18. PRINTER CONNECTOR

**LPT1:** LPT Connector.

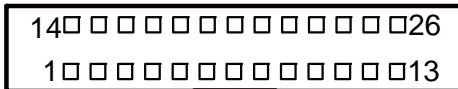

**LPT1**

The assignments are as follows:

PIN	ASSIGNMENT	PIN	ASSIGNMENT
1	STBJ	14	ALFJ
2	PDR0	15	ERRJ
3	PDR1	16	PAR_INITJ
4	PDR2	17	SLCTINJ
5	PDR3	18	GND
6	PDR4	19	GND
7	PDR5	20	GND
8	PDR6	21	GND
9	PDR7	22	GND
10	ACKJ	23	GND
11	BUSY	24	GND
12	PE	25	GND
13	SLCTJ	26	NC



## 2-19. LVDS Connector

LVDS1: LVDS Connector

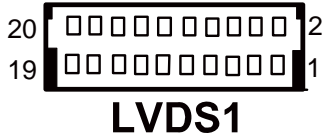

The pin assignments are as follows:

PIN	ASSIGNMENT	PIN	ASSIGNMENT
1	GND	2	LVDS_VCC
3	LVDS_YAP2	4	LVDS_VCC
5	LVDS_YAM2	6	GND
7	GND	8	GND
9	LVDS_YAP1	10	LVDS_CLKAP
11	LVDS_YAM1	12	LVDS_CLKAM
13	GND	14	GND
15	LVDS_YAP0	16	GND
17	LVDS_YAM0	18	LVDS_VCC
19	GND	20	LVDS_VCC

**LVDS2:** LVDS Connector.

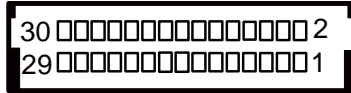

**LVDS2**

The pin assignments are as follows:

<b>PIN</b>	<b>ASSIGNMENT</b>	<b>PIN</b>	<b>ASSIGNMENT</b>
1	LVDS_VCC	2	GND
3	NC	4	NC
5	GND	6	NC
7	NC	8	GND
9	NC	10	NC
11	NC	12	NC
13	NC	14	NC
15	GND	16	CLKO+
17	CLKO-	18	GND
19	RINO2+	20	RINO2-
21	GND	22	RINO1+
23	RINO1-	24	GND
25	RINO0+	26	RINO0-
27	NC	28	NC
29	LVDS_VCC	30	LVDS_VCC

## 2-20. SATA CONNECTOR

**SATA1:** Serial ATA Connector

The pin assignments are as follows:

PIN	ASSIGNMENT
1	G1
2	TX+
3	TX-
4	G2
5	RX-
6	RX+
7	G3

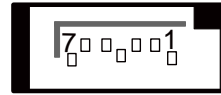

**SATA1**

## 2-21. SATA POWER CONNECTOR

**JPWR\_4P1:** Serial ATA Connector

The pin assignments are as follows:

PIN	ASSIGNMENT
1	VCC
2	GND
3	GND
4	VCC12

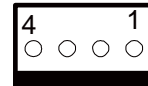

**JPWR\_4P1**

## 2-22. TOUCH PANEL CONNECTOR

**TOUCH1:** Touch Panel Connector  
 The pin assignments are as follows:

PIN	ASSIGNMENT
1	LR (Low Right)
2	LL (Low Left)
3	Probe
4	UR (Up Right)
5	UL (Up Left)

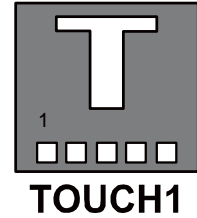

## 2-23. TOUCH PANEL SELECTION

**JP16:** Touch Panel Selection.  
 The selections are as follows:

SELECTION	JUMPER SETTINGS	JUMPER ILLUSTRATION
e-Turbo	1-2 & 5-6	<p><b>JP16</b></p>
Elo	3-4 & 7-8	<p><b>JP16</b></p>

\*\*\* Factory default --- Elo.

## 2-24. TOUCH PANEL INTERFACE TYPE SELECTION

### JP15: Touch Panel Type Selection

The selections are as follows:

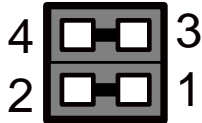
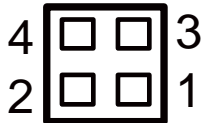

SELECTION	JUMPER SETTINGS	JUMPER ILLUSTRATION
USB	1-2 3-4	 <b>JP15</b>
RS-232	NC	 <b>JP15</b>

\*\*\* Manufactory default --- USB.

## 2-25. CLEAR CMOS DATA SELECTION

### JP1: Clear CMOS Data Selection

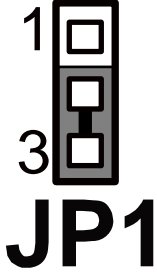
The selections are as follows:

FUNCTION	JUMPER SETTING (pin closed)	JUMPER ILLUSTRATION
CLEAR CMOS	2-3	 <p>The diagram shows a three-pin header labeled JP1. Pin 1 is at the top, pin 3 is in the middle, and pin 2 is at the bottom. A grey shaded rectangle covers pins 2 and 3, indicating they are connected.</p>
NORMAL	1-2	 <p>The diagram shows a three-pin header labeled JP1. Pin 1 is at the top, pin 3 is in the middle, and pin 2 is at the bottom. A grey shaded rectangle covers pins 1 and 2, indicating they are connected.</p>

\*\*\* Manufacturing Default – Normal.

 To clear CMOS data, user must power-off the computer and set the jumper to “Clear CMOS” as illustrated above. After five to six seconds, set the jumper back to “Normal” and power-on the computer.

## 2-26. Compact Flash Connector

**CF1:** Compact Flash Connector.

The pin assignments are as follows:

<b>PIN</b>	<b>ASSIGNMENT</b>	<b>PIN</b>	<b>ASSIGNMENT</b>
1	GND	26	GND
2	D03	27	D11
3	D04	28	D12
4	D05	29	D13
5	D06	30	D14
6	D07	31	D15
7	CSJ1	32	CSJ3
8	GND	33	GND
9	GND	34	SDIORDJ
10	GND	35	SDIOWRJ
11	GND	36	+5V
12	GND	37	IRQ14
13	+5V	38	+5V
14	GND	39	-CSEL
15	GND	40	NC
16	GND	41	RESETJ
17	GND	42	IORDJ
18	A02	43	REQ
19	A01	44	ACKJ
20	A00	45	CF_LEDJ
21	D00	46	-PDIAG
22	D01	47	D08
23	D02	48	D09
24	NC	49	D10
25	GND	50	GND

# ***SOFTWARE UTILITIES***

## **CHAPTER 3**

This chapter comprises the detailed information of VGA driver, LAN driver, and Sound driver. It also describes the OS support table.

Section includes:

- Intel® Chipset Software Installation Utility
- VGA Driver Utility
- LAN Driver Utility
- Sound Driver Utility
- Touch Screen Driver Utility
- OS Support Table



### **3-1. INTRODUCTION**

Enclosed with our POS-3520 package is our driver utility, which may come in a form of a CD ROM disc or floppy diskettes. For CD ROM disc user, you will only need some of the files contained in the CD ROM disc, please kindly refer to the following chart:

<b>Filename (Assume that CD ROM drive is D:)</b>	<b>Purpose</b>
D:\Driver\UTILITY	Intel® Chipset Software Installation Utility
D:\Driver\VGA	Intel® Graphics Media Accelerator 3150 For VGA driver installation
D:\Driver\LAN	Realtek 8111DL For LAN Driver installation
D:\Driver\Sound	Realtek ALC888 For Sound driver installation
D:\Driver\TOUCH	Elo Touch driver installation

⚠ User should remember to install the Utility right after the OS is fully installed.

## 3-2. INTEL® CHIPSET SOFTWARE INSTALLATION UTILITY

### 3-2-1. Introduction

The Intel® Chipset Software Installation Utility installs to the target system the Windows\* INF files that outline to the operating system how the chipset components will be configured. This is needed for the proper functioning of the following features:

- Core PCI and ISAPNP Services
- AGP Support
- SATA Storage Support
- USB Support
- Identification of Intel® Chipset Components in Device Manager

### 3-2-2. Installation of Utility for Windows XP, Windows 7 32Bit, Windows 64Bit, POSReady2009

The Utility Pack is to be installed only for Windows XP, Windows 7 32bit, Windows 7 64bit, POSReady 2009 program.

It should be installed right after the OS installation, kindly follow the following steps:

1. Please insert the Utility Disk into Floppy Disk Drive A/B or CD ROM drive.
2. Under Windows XP, Windows 7 32bit, Windows 7 64bit, POSReady 2009 system, go to the directory where Utility Disc is located.
3. Click **Setup.exe** file for utility installation.
4. Follow the instructions on the screen to complete the installation.

Once installation is completed, shut down the system and restart it in order to complete the changes.

### 3-3. VGA DRIVER UTILITY

The VGA interface embedded with our POS-3520 can support a wide range of display. You can display CRT, LVDS simultaneously with the same mode.

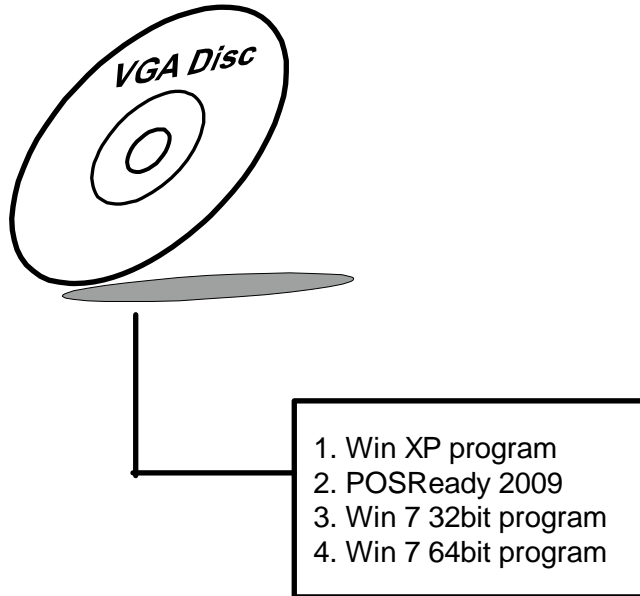

#### 3-3-1. Installation of VGA Driver:

To install the VGA Driver, simply follow the following steps:

1. Please insert the Utility Disk into Floppy Disk Drive A/B or CD ROM drive.
2. Under Windows XP, Windows 7 32bit, Windows 7 64bit, POSReady 2009 system, go to the directory where VGA driver is located.
3. Click **Setup.exe** file for VGA driver installation.
4. Follow the instructions on the screen to complete the installation.
5. Once installation is completed, shut down the system and restart it in order to complete the changes.

## 3-4. LAN DRIVER UTILITY

### 3-4-1. Introduction

POS-3520 is enhanced with LAN function that can support various network adapters. Installation programs for LAN driver is listed as follows:

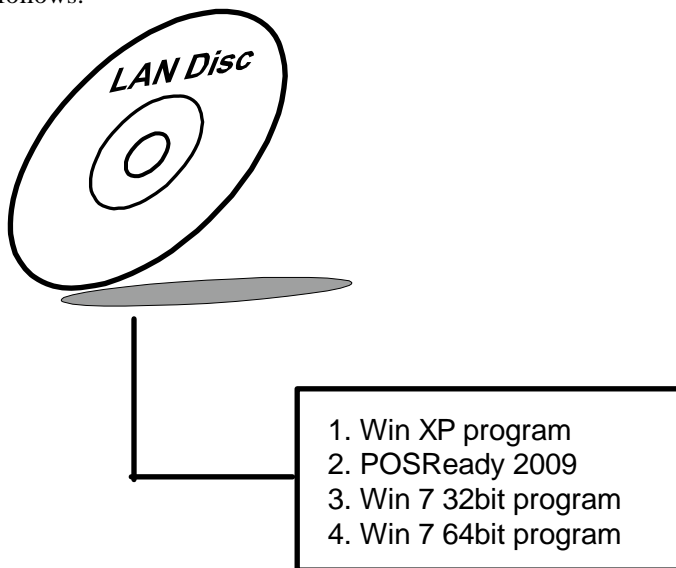

**For more details on Installation procedure, please refer to *Readme.txt* file found on LAN DRIVER UTILITY.**

### 3-5. SOUND DRIVER UTILITY

#### 3-5-1. Introduction

The sound function enhanced in this system is fully compatible with Windows XP, Windows 7 32bit, Windows 7 64bit and POSReady 2009. Below, you will find the content of the Sound driver :

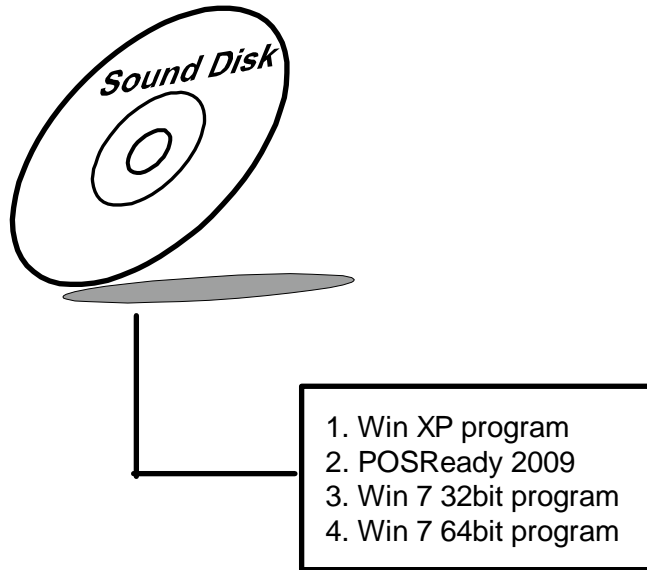

#### 3-5-2. Installation Procedure

To install, kindly refer to the readme.txt file on the Driver Disc (:\Sound\Realtek\Readme.txt).

### 3-6. TOUCHSCREEN DRIVER UTILITY

The touchscreen driver utility is to be installed only for Windows XP, Windows 7 32bit, Windows 7 64bit, POSReady 2009 program.

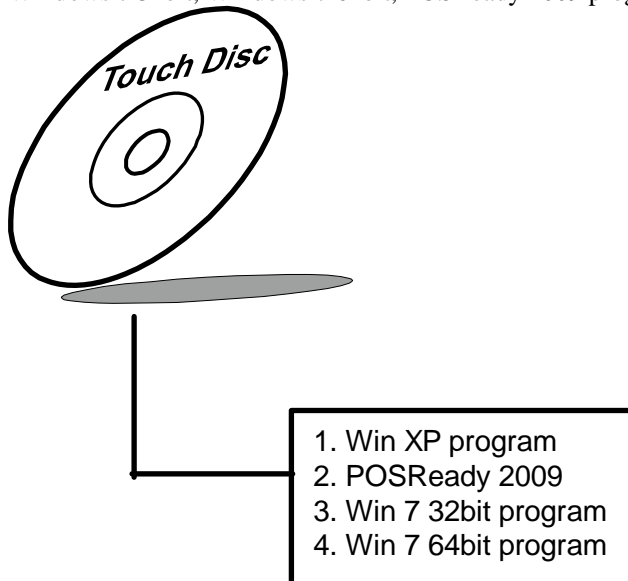

It should be installed right after the OS installation, kindly follow the following steps:

1. Please insert the Utility Disk into Floppy Disk Drive A/B or CD ROM drive.
2. Under Windows XP, Windows 7 32bit, Windows 7 64bit, POSReady 2009 system, go to the directory where Utility Disc is located.
3. Click **Setup.exe** file for utility installation.
4. Follow the instructions on the screen to complete the installation.
5. Once installation is completed, shut down the system and restart it in order to complete the changes.

### **3-7 OS SUPPORT TABLE**

<b>Operating System</b>	<b>Version</b>	<b>Language</b>	<b>Company</b>
Windows XP Professional	SP3	English	Microsoft
WEPOS	1.0	English	Microsoft
POS Ready 2009	1.0	English	Microsoft
Windows 7 32bit	Ultimate	English	Microsoft
Windows 7 64bit	Ultimate	English	Microsoft
Fedora Core	14	English	Linux
Ubuntu	11.04	English	Linux

# ***AMI BIOS SETUP***

CHAPTER

**4**

This chapter shows how to setup the AMI BIOS.

Section includes:

- Introduction
- Entering Setup
- Main
- Advanced
- Boot
- Security
- Chipset
- Exit



## **4-1. INTRODUCTION**

This chapter will show you the function of the BIOS (Basic Input and Output System) in managing the features of your system. The POS-3520 POS Terminal is equipped with the BIOS from AMI (American Megatrends Inc). The following pages describe how to use the BIOS for configure system hardware by BIOS Setup menu.

When the PC starts up, the first job for the BIOS is to initialize and identify system devices such as the video display card, keyboard and mouse, hard disk, CD/DVD drive and other hardware. The BIOS then locates software held on a peripheral device (designated as a 'boot device'), such as a hard disk or a CD, and loads and executes that software, giving it control of the PC.

BIOS code is stored on a non-volatile, ROM chip built into the system, on the mother board and the BIOS software is specifically designed to work with the particular type of system in question including having a knowledge of the workings of various devices that make up the complementary chipset of the system

BIOS also provide a user interface, this is a menu system accessed by pressing a certain key on the keyboard when the PC starts. In the BIOS UI, a user can configure hardware, set the system clock, enable or disable system components, and most importantly, select which devices are eligible to be a potential boot device and set various password prompts, most importantly a password for securing access to the BIOS UI functions itself and preventing malicious users from booting the system from unauthorized peripheral devices.

The following diagram illustrates the relationships between system hardware, BIOS, operating system, and application program:

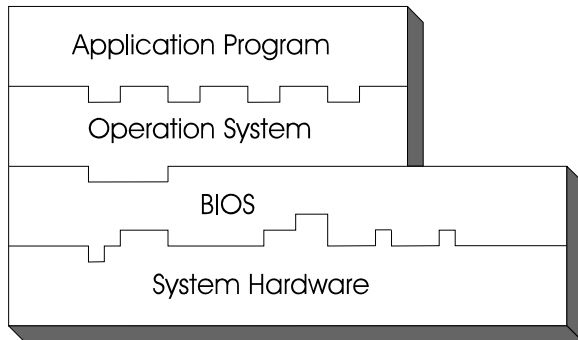

## 4-2 ENTERING SETUP

When system powered on, BIOS will enter the Power-On Self Test (POST) routines and displays below message on the screen:



### POST Screen

As long as this logo is present on the screen you may press the <Del> key (the one that shares the decimal point at the bottom of the number keypad) to enter the BIOS setup program. In a moment, the main menu of the AMI SETUP program will be shown on the screen:

BIOS SETUP UTILITY					
Main	Advanced	Boot	Security	Chipset	Exit
<b>System Overview</b>					Use [ENTER], [TAB] or [SHIFT-TAB] to select a field.
<b>AMIBIOS</b>					Use [+] or [-] to configure system Time.
Version	:35200T04				
Build Date	: 04/28/11				
<b>Processor</b>					
Intel(R) Atom(TM) CPU	D525	@1.80GHz			
Speed	:1800MHz				
Count	: 1				
<b>System Memory</b>					←→ Select Screen
Size	: 1014MB				↓↑ Select Item
System Time [01:57:52]					+- Change Field
System Date [Wed 04/29/2011]					Tab Select Field
					F1 General Help
					F10 Save and Exit
					ESC: Exit
v02.68 (c)Copyright 1985-2009 American Megatrends, Inc.					

**Setup program initial screen**

You may move the cursor by up/down keys to highlight the individual menu items. As you highlight each item, a brief description of the highlighted selection will appear at the bottom of the screen.

## 4-3. Main

BIOS SETUP UTILITY					
Main	Advanced	Boot	Security	Chipset	Exit
<b>System Overview</b>		Use [ENTER], [TAB] or [SHIFT-TAB] to select a field.			
<b>AMIBIOS</b>		Use [+] or [-] to configure system Time.			
Version	:35200T04				
Build Date	: 04/28/11				
<b>Processor</b>					
Intel(R) Atom(TM) CPU	D525	@1.80GHz			
Speed	:1800MHz				
Count	: 1				
<b>System Memory</b>					
Size	: 1014MB				
System Time	[01:57:52]				
System Date	[Wed 04/29/2011]				
		←→	Select Screen		
		↓↑	Select Item		
		+ -	Change Field		
		Tab	Select Field		
		F1	General Help		
		F10	Save and Exit		
		ESC	Exit		
v02.68 (c)Copyright 1985-2009 American Megatrends, Inc.					

**Main Screen**

use <↑> or <↓> arrow keys to highlight the item and key in the value you want in each item. This menu provides basic system configurations, such as time and date.

**AMI BIOS, Processor, System Memory**

This items show the BIOS version, BIOS build up date, processor and system memory information of your system.

**System Time**

This setting allows you to set the system time. The format is [Hour: Minute: Second]. User can directly key-in value or use <+> or <-> arrow keys to increase/decrease it.

### System Date

This setting allows you to set the system date. The format is [Day Month/Date/ Year]. User can directly key-in value or use <+> or <-> arrow keys to increase/decrease it.

## 4-4. Advanced

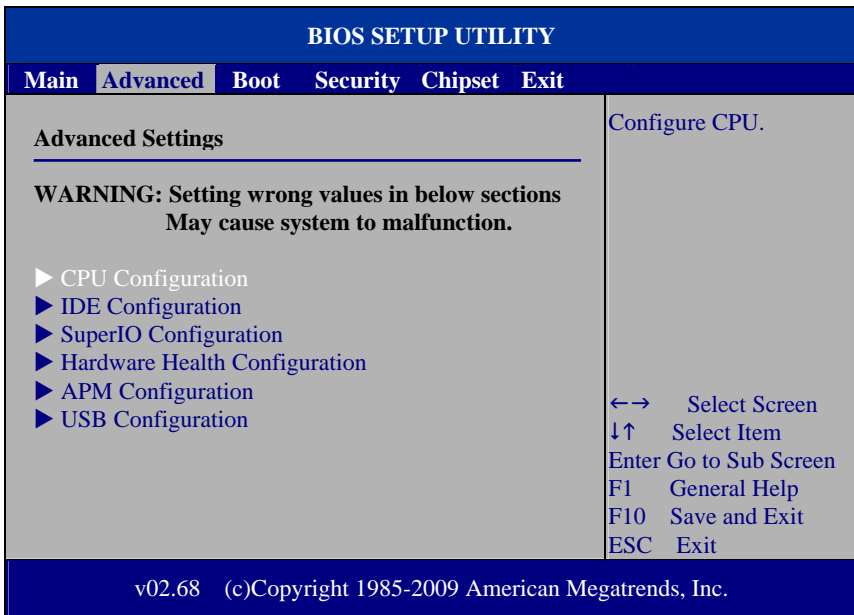

### Advanced Screen

This menu provides advanced configurations such as CPU Configuration, IDE Configuration, SuperIO Configuration...etc.

### 4-4.1. CPU Configuration

BIOS SETUP UTILITY	
Advanced	
<p><b>Configure advanced CPU settings</b> Module Version: 3F. 1C</p> <hr/> <p>Manufacturer: Intel Intel(R) Atom(TM) CPU D525 @ 1.80GHz Frequency : 1.80GHz FSB Speed : 800MHz Cache L1 : 48 KB Cache L2 : 1024 KB Ratio Actual Value : 9</p> <p>Hyper Threading Technology [Enabled]</p>	<p>Enabled for Windows XP and Linux4 (OS optimized for Hyper Threading Technology) and disabled for other OS (OS not optimized for Hyper-Threading Technology)</p> <p>←→ Select Screen ↓↑ Select Item +- Change Option F1 General Help F10 Save and Exit ESC: Exit</p>
v02.68 (c)Copyright 1985-2009 American Megatrends, Inc.	

#### CPU Configuration Screen

This menu provides some information about CPU.

#### Hyper Threading Technology

Hyper Threading is Intel's term for its simultaneous multithreading implementation in their CPUs. Enable this function will improve parallelization of computation performed on PC microprocessor. For each processor core that is physically present, the operation system addresses two virtual processors, and shares the workload between them when possible.

### 4-4.2. IDE Configuration

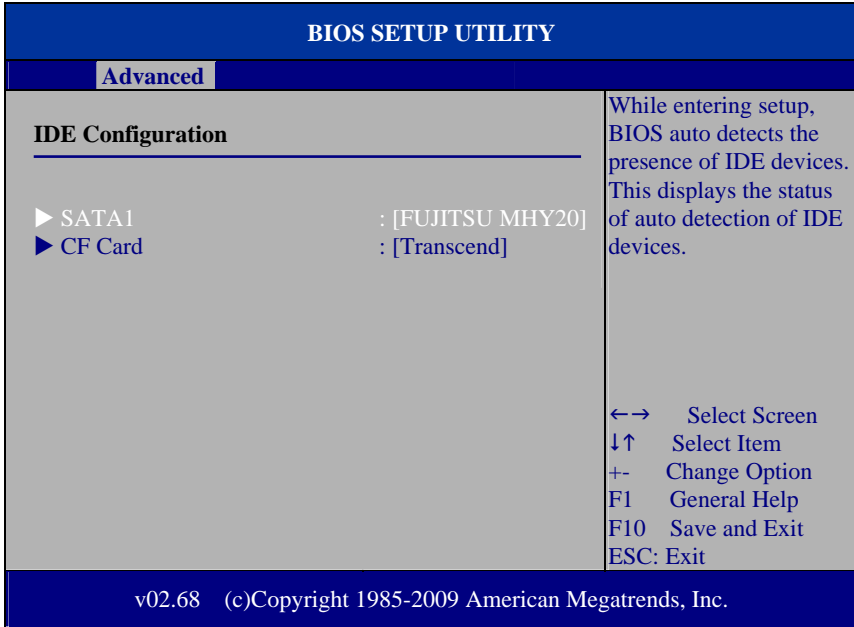

#### IDE Configuration Screen

This menu provides advanced IDE configuration for hard drive. The control items of SATA 1 / CF Card are all the same and describe in next section.

#### SATA 1/ CF Card

This setting displays the status of storages.

## 4-4.2.1 SATA 1 and CF Card

BIOS SETUP UTILITY	
Advanced	
<b>SATA 1</b>	
Select the type of device connected to the system.	
Device	: Hard Disk
Vendor	: FUJITSU MHY2040BH ESW
Size	: 40.0GB
LBA Mode	: Supported
Block Mode	: 16 Sectors
PIO Mode	: 4
Async DMA	: MultiWord DMA-2
Ultra DMA	: Ultra DMA-5
S.M.A.R.T.	: Supported
Type	[Auto]
LBA/Large Mode	[Auto]
Block (Multi-Sector Transfer)	[Auto]
PIO Mode	[Auto]
DMA Mode	[Auto]
S.M.A.R.T.	[Auto]
32Bit Data Transfer	[Enabled]
←→ Select Screen ↓↑ Select Item +- Change Option F1 General Help F10 Save and Exit ESC: Exit	
v02.68 (c)Copyright 1985-2009 American Megatrends, Inc.	

**SATA 1 Screen****Type**

Select the type of device connected to the system.

**LBA/Large Mode**

Enabling LBA causes Logical Block Addressing to be used in place of Cylinders, Heads and Sectors.



**Block (Multi-Sector Transfer)**

Any selection except Disabled determines the number of sectors transferred per block.

**PIO Mode**

Configure the type of PIO (Programmed Input/Output) mode 0-4 for IDE device. Mode 0 through 4 provides successively increased performance.

**DMA Mode**

Select the type of Ultra DMA mode on a hard drive.

**S.M.A.R.T**

This allows you to activate the S.M.A.R.T. (Self-Monitoring Analysis & Reporting Technology) capability for the hard disks. S.M.A.R.T is a utility that monitors your disk status to predict hard disk failure. This gives you an opportunity to move data from a hard disk that is going to fail to a safe place before the hard disk becomes offline.

**32Bit Data Transfer**

Enables/Disable 32-bit data transfer.

## 4-4.3. SuperIO Configuration

BIOS SETUP UTILITY	
Advanced	
<b>Configure Win627UHG Super IO Chipset</b>	
Watchdog Function	[Disabled]
Serial Port1 Address	[2F8]
Serial Port1 IRQ	[IRQ3]
Serial Port2 Address	[3F8]
Serial Port2 IRQ	[IRQ4]
Serial Port3 Address	[3E8]
Serial Port3 IRQ	[IRQ11]
Serial Port4 Address	[2E8]
Serial Port4 IRQ	[IRQ10]
Parallel Port Address	[378]
Parallel Port Mode	[Normal]
Parallel Port IRQ	[IRQ7]
Allows BIOS to Select WDTO function.	
←→ Select Screen ↓↑ Select Item +- Change Option F1 General Help F10 Save and Exit ESC: Exit	
v02.68 (c)Copyright 1985-2009 American Megatrends, Inc.	

## SuperIO Configuration Screen

**\* WatchDog function**

If system hang or not respond for user, enable watchdog function can triggers a system reset by an user given value count down to zero.

**Serial Port1~4 Address**

Select IO address as serial ports default resource.

**Serial Port1~4 IRQ**

Select IO IRQ as serial ports default resource.

**Parallel Port Address**

Select IO address for parallel ports resource allocation.

**Parallel Port Mode**

Select the operation mode for parallel port.

**Parallel Port IRQ**

Select IRQ for parallel ports resource allocation.

**4-4.4. Hardware Health Configuration**

BIOS SETUP UTILITY		
Advanced		
<b>Hardware Health Configuration</b>		Fan configuration mode setting
SYS Temperature	: 35°C /95°F	
CPU Temperature	:33°C /91°F	
CPUFAN Speed	: 6026 RPM	
Vcore	: 1.024 V	
12V	: 11.776 V	
5V	: 5.088 V	
1.05V	: 1.0249 V	
VSB	: 5.140 V	
		←→ Select Screen ↓↑ Select Item +- Change Option F1 General Help F10 Save and Exit ESC Exit
v02.68 (c)Copyright 1985-2009 American Megatrends, Inc.		

**Hardware Health Configuration**

**System Temperature / CPU Temperature**

Both section show System and CPU current temperature.

**CPUFAN Speed**

This item shows CPU fan speed.

**VCORE / 12V / 5V / 1.05V /VSB**

These items provide hardware health information.

#### 4-4.5. APM Configuration

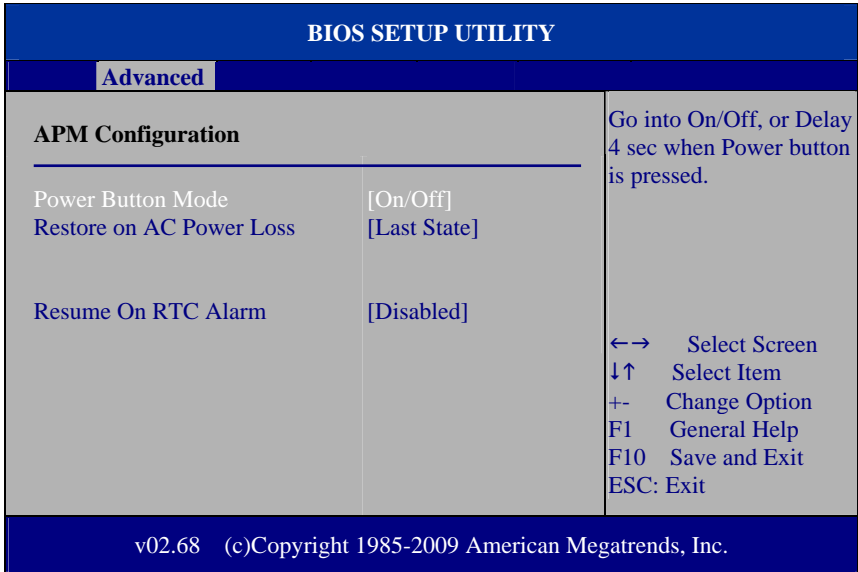

**APM Configuration Screen**

#### Power Management/APM

This is the main control item for enable/disable below APM functions.

#### Power Button Mode

This setting controls shutdown action by pressing power button. The system will be shutdown immediately after pressing power button when set to “On/Off”. If set the power button mode to “Delay 4 seconds”, system will be shutdown after pressing and hold the power button over 4 seconds.

#### Restore on AC/Power Loss

Once a power failure situation happens, this item decides the system power state after AC power restore back.

#### Resume On RTC Alarm

When user set this option to [Enable], it allows system to be wake up at specific date/time.

**RTC Alarm Date (Days)**

Set a specific date value for RTC alarm function to wakeup system from soft off state.

**System Time**

Set a specific time value for RTC alarm function to wakeup system from soft off state.

**4-4.6.USB Configuration**

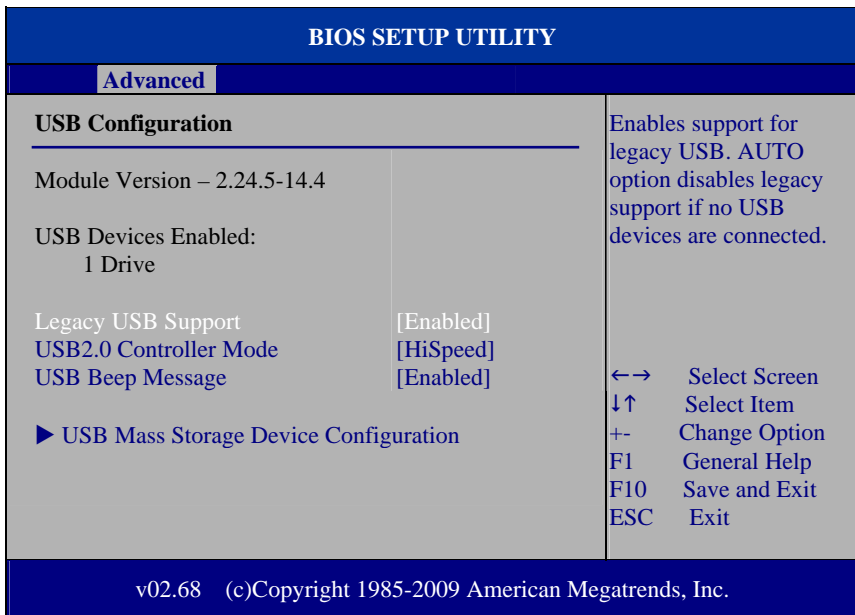

**USB Configuration Screen**

**Legacy USB Support**

Set to [Enabled] if you want to use USB device in the legacy operating system, such as MS-DOS or SCO Unix.

**USB 2.0 Controller Mode**

Configure the onboard USB 2.0 controller operation mode to high Speed or full speed mode.

### USB Beep Message

System will generate beep sound during USB device enumeration.

#### 4-4.6.1 USB Mass Storage Device Configuration

BIOS SETUP UTILITY		
Advanced		
<b>USB Mass Storage Device Configuration</b>		If Auto, USB devices less than 530MB will be emulated as Floppy and remaining as hard drive. Forced FDD option can be used to force a HDD formatted drive to boot as FDD. (Ex. ZIP drive).  ←→ Select Screen ↓↑ Select Item +- Change Option F1 General Help F10 Save and Exit ESC: Exit
Device #1	USB2.0 USB Flash Disk	
Emulation Type	[Auto]	
v02.68 (c)Copyright 1985-2009, American Megatrends, Inc.		

### Emulation Type

Select which type of device that USB mass storage emulation. When user select to [Auto], the USB storage size less than 530MB will be emulated as floppy drive and remaining as hard drive.

## 4-5. Boot

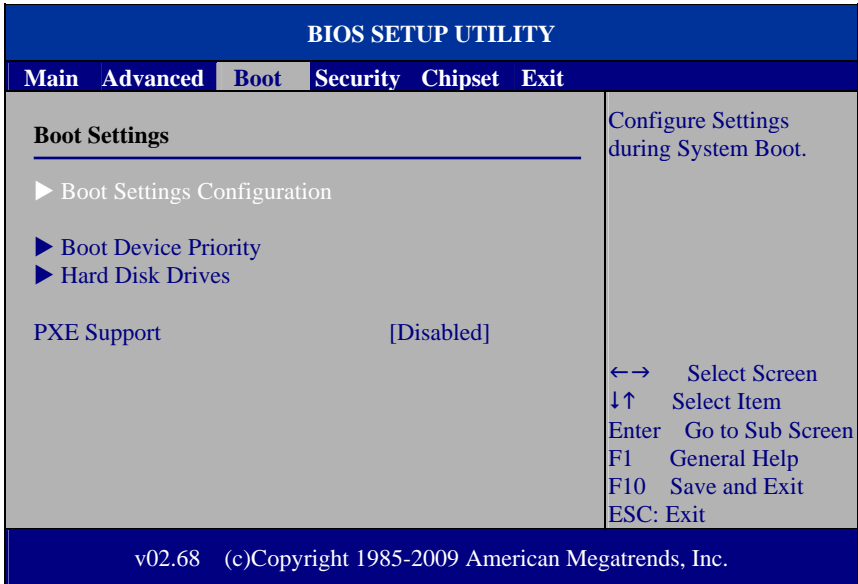

### Boot Screen

This menu provides control items for system boot configuration.

### PXE Support

This is the main control item for enable/disable PXE (Preboot Execution Environment) support.

### 4-5.1 Boot Settings Configuration

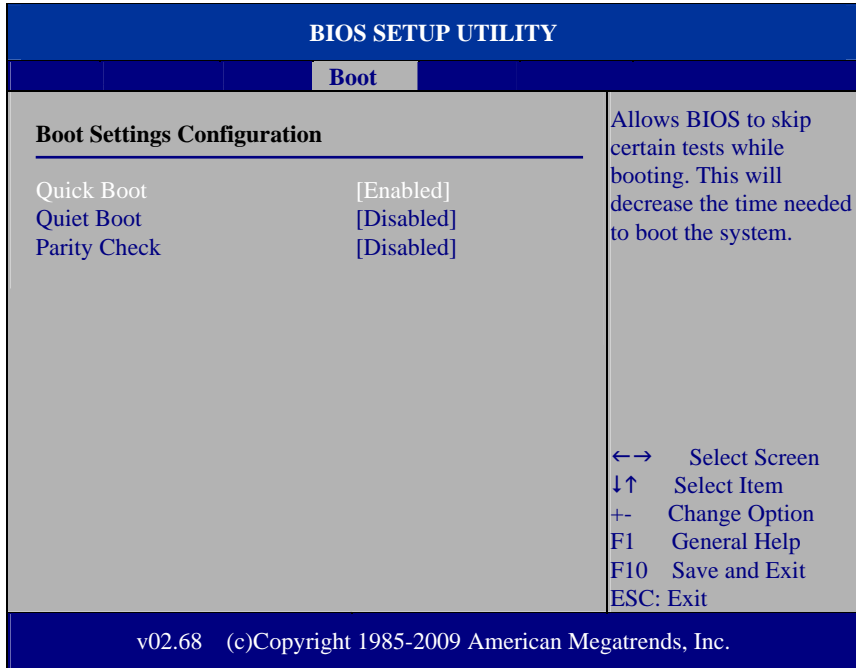

**Boot Settings Configuration Screen**

#### Quick Boot

Enable this item allows BIOS POST to skip some tests during boot-up for saving boot time.

#### Quiet Boot

When set this option to [disabled], BIOS will display normal POST messages.

#### Parity Check

This setting enables or disables memory or parity error check.



4-5.2 Boot Device Priority

BIOS SETUP UTILITY	
Boot	
<b>Boot Device Priority</b>	Specify the boot sequence from the available devices.
1st Boot Device [USB: USB2.0 USB Fla]	A device enclosed in parenthesis has been disabled in the corresponding type menu.
	←→ Select Screen ↓↑ Select Item +- Change Option F1 General Help F10 Save and Exit ESC: Exit
v02.68 (c)Copyright 1985-2009 American Megatrends, Inc.	

**Boot Device Priority Screen**

**1<sup>st</sup> / 2<sup>nd</sup> / 3<sup>rd</sup> ...Boot Device**

Choose the boot sequence from the available devices..

## 4-5.3 Boot Device Priority

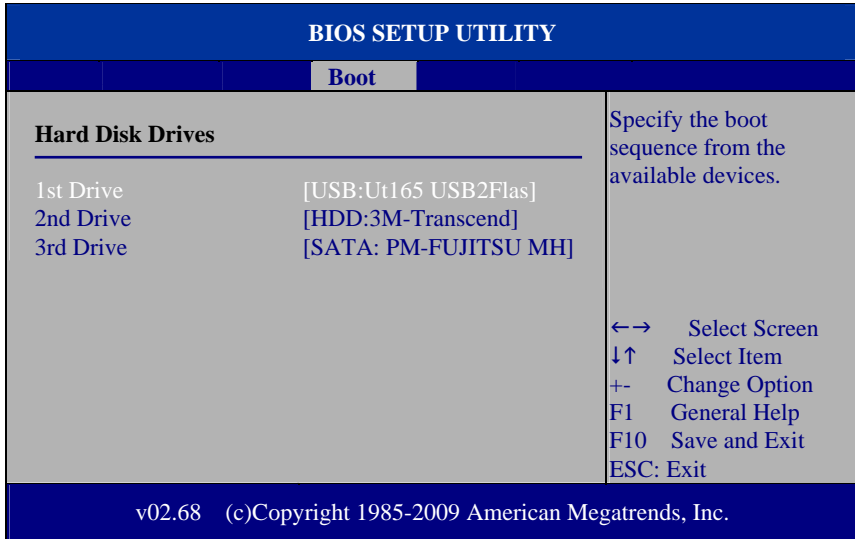
**Hard Disk Drives Screen****1<sup>st</sup> / 2<sup>nd</sup> ...Drive**

This setting allows user to set the priority of hard drive or another bootable USB storages. Press <Enter> to enter the sub-menu and press <↑> or <↓> arrow keys to select the device. Another way is to press <+> or <-> to move it up/down in the priority list.

## 4-6. Security Settings

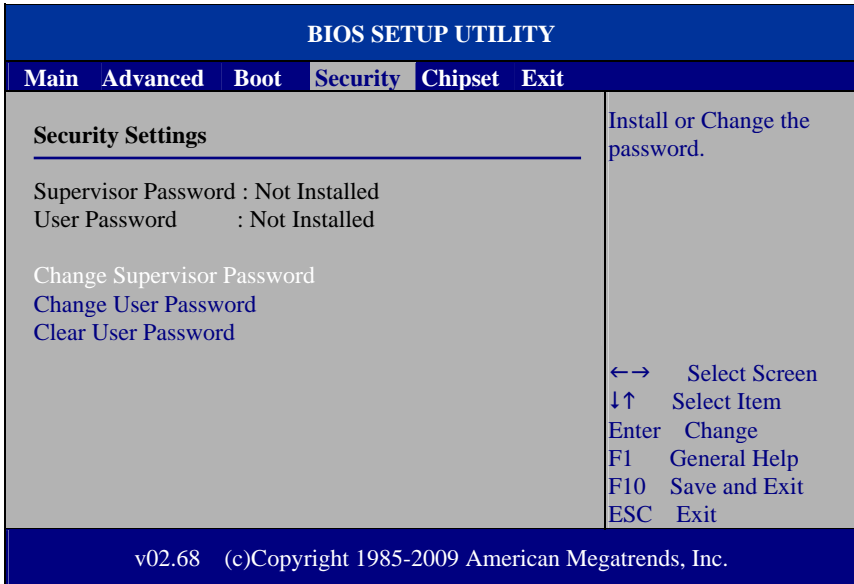

**Security Settings Screen**

### Change Supervisor Password

Supervisor Password controls the access right to the BIOS Setup utility. These settings allow user to set or change the supervisor password.

### Change User Password

User Password controls system access right when power on. These settings allow user to set or change the user password.

## 4.7 Chipset

BIOS SETUP UTILITY					
Main	Advanced	Boot	Security	Chipset	Exit
<b>Advanced Chipset Settings</b>		Configure North Bridge features.			
WARNING: Setting wrong values in below sections may cause system to malfunction.					
▶ North Bridge Configuration					
▶ South Bridge Configuration					
		←→ Select Screen			
		↓↑ Select Item			
		Enter Go to Sub Screen			
		F1 General Help			
		F10 Save and Exit			
		ESC: Exit			
v02.68 (c)Copyright 1985-2009 American Megatrends, Inc.					

### Advanced Chipset Settings Screen

### 4-7.1 North Bridge Chipset Configuration

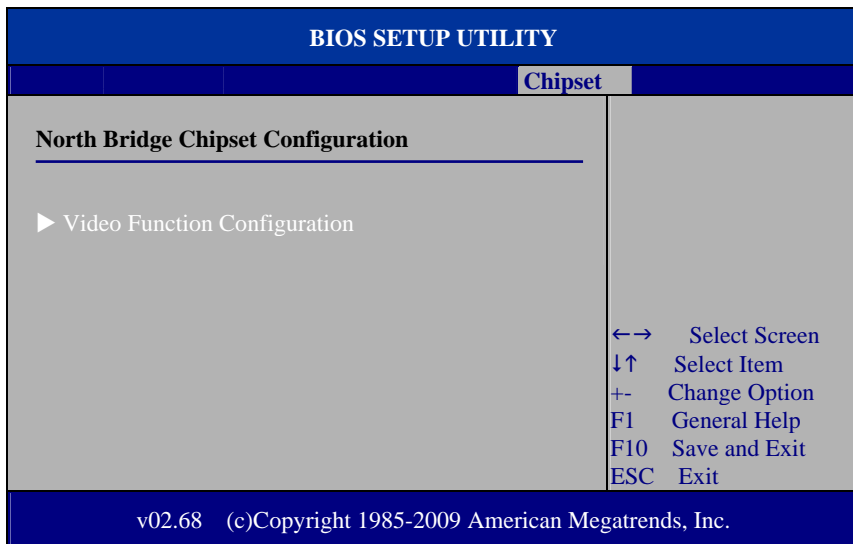

### North Bridge Chipset Configuration

## 4-7.1.1 Video Function Configuration

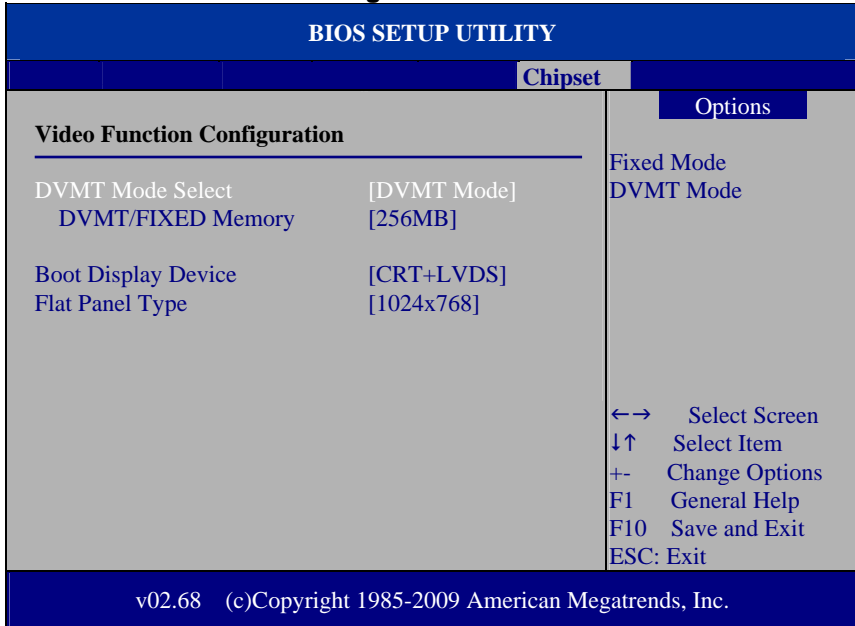

## Video Function Configuration Screen

**DVMT Mode Select / DVMT/FIXED Memory**

Intel's Dynamic Video Memory Technology (DVMT) allows the system to dynamically allocated memory resources according to the demands of the system at any point in time. The key idea in DVMT is to improve the efficiency of the memory allocated to either system or graphics processor. It is recommended that you set this BIOS feature to DVMT Mode for maximum performance. Setting it to DVMT Mode ensures that system memory is dynamically allocated for optimal balance between graphics and system performance.

**Boot Display Device**

Choose the default boot display device by user requirement such as [CRT], [LVDS] and [CRT+LVDS]

**Flat Panel Type**

Select the resolution for the connected LVDS panel such as [800x600] and [1024x768].

**4-7.2 South Bridge Configuration**

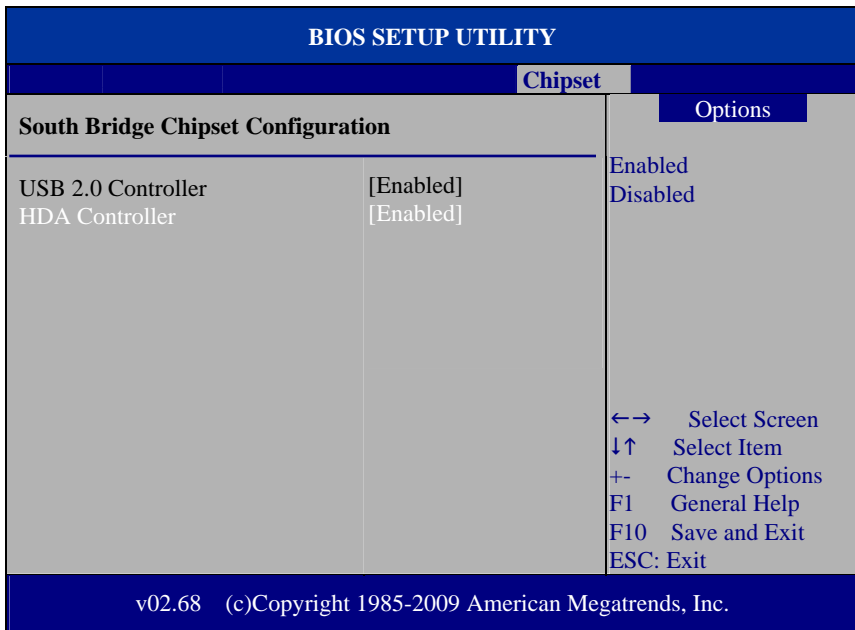

**South Bridge Chipset Configuration Screen**

**USB 2.0 Controller**

Enable or disable the USB 2.0 Controller.

**HDA Controller**

Enable or disable the onboard High-definition Audio controller.

## 4.8 Exit

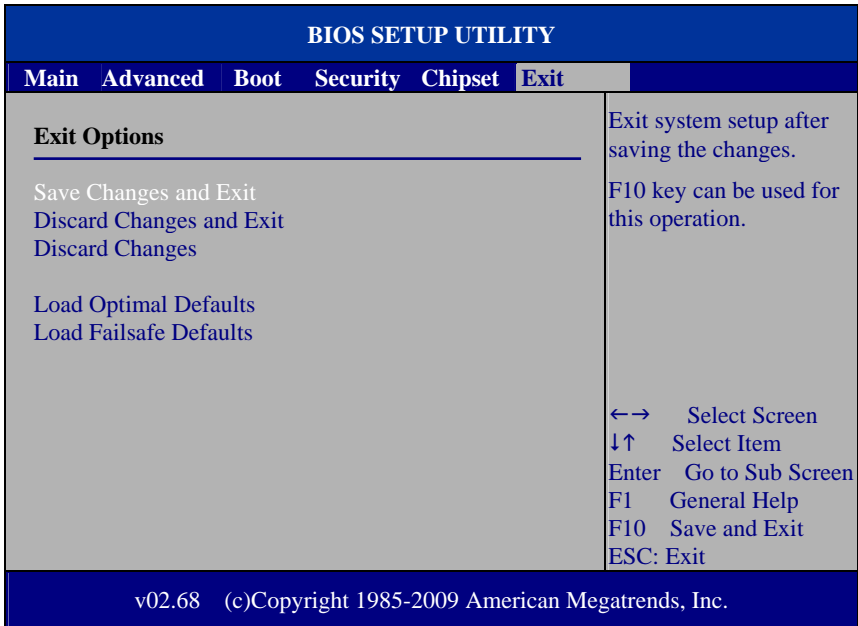

### Exit Screen

#### Save Changes and Exit

Save changes to CMOS and then exit the BIOS setup screen. User can also press the [F10] key for this operation.

#### Discard Changes and Exit

Abandon all changes and exit the BIOS setup screen. User can also press the [ESC] key for this operation.

#### Discard Changes

Discard all changes done so far to the setup items. User can press the [F7] key for this operation.



**Load Optimal Defaults**

Press <Enter> on this item, it will show a confirmation dialog box with a message like below:

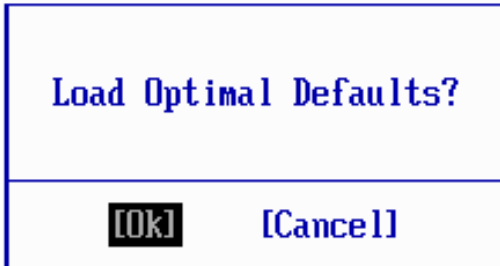

Pressing "Ok" to loads the factory recommended optimal setting for system operations. User can also press the [F9] key for this operation.

**Load Failsafe Defaults**

Press <Enter> on this item, it will show a confirmation dialog box with a message like below:



To use the BIOS failsafe default values, change the prompt to "Ok" and press the <Enter > key. User can also press the [F8] key for this operation.

# ***SYSTEM ASSEMBLY***

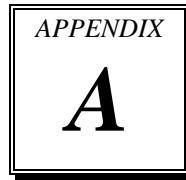

This appendix contains exploded diagram of the system.

Section includes:

- Exploded Diagram for 2 Inch Thermal Printer Remove/ Install
- Exploded Diagram for 3 Inch Thermal Printer Remove/ Install
- Exploded Diagram for MSR & Fingerprint Remove/ Install
- Exploded Diagram for Fingerprint Module
- Exploded Diagram for POS-3520 Hard Disk Drive Remove/ Install
- Exploded Diagram for POS-3520 LCD Panel Remove/ Install
- Exploded Diagram for POS-3520 Mini-PCIE Installation
- Exploded Diagram for POS-3520 Motherboard
- Exploded Diagram for POS-3520 MSR Module
- Exploded Diagram for POS-3520 MSR & LCD Assembly
- Exploded Diagram for POS-3520 Printer Assembly
- Exploded Diagram for POS-3520 Top Cover Assembly
- Exploded Diagram for POS-3520 VFD Module Assembly

# EXPLODED DIAGRAM FOR 2 INCH THERMAL PRINTER REMOVE/ INSTALL

2" Printer Assembly

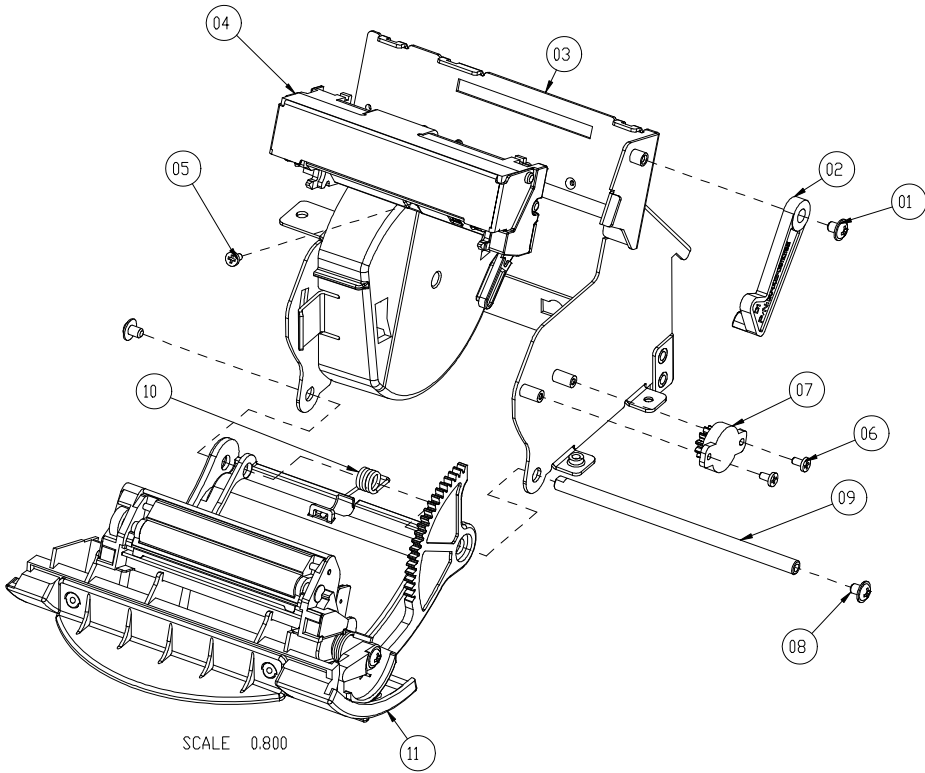

12	ADD_PAPER_WALL	30-002-28310165	--	1
11	Paper_cover_Assembly	SEE PAGE 19	--	1
10	PS3100-SPRING-1	23-002-00000701	--	1
9	Paper_cover_pin	20-004-10011165	--	1
8	M3_L5_Washer_Ni	22-242-30005311	7~8kgf-cm	2
7	ROTARY DAMPER	30-022-09110000	--	1
6	M2_L4_I_Ni	22-272-20004011	6~7kgf-cm	2
5	M2_L4_I_Ni	22-272-20004011	6~7kgf-cm	2
4	CAPD24X_A_03 (2")	52-701-00020003	--	1/2
3	PS3100_PRINTER_BOX3	20-040-03003165	--	1
2	Printer_add_arm	30-002-09110165	--	1
1	M3_L5_Washer_Ni	22-242-30005311	7~8kgf-cm	1
No.	Name	P/N No.	Torsion	Qt'y

2" Printer Cover Assembly

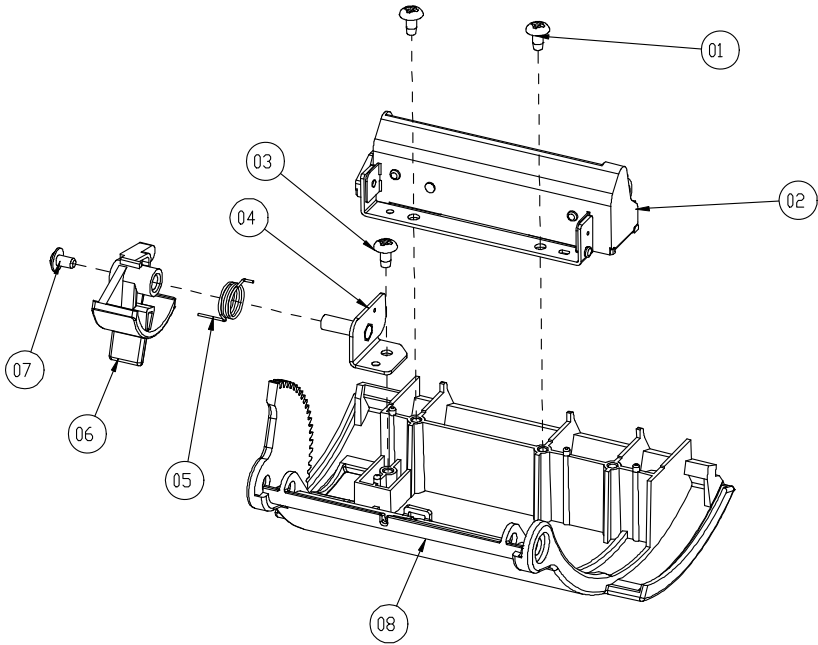

8	PS3100_PAPER_COVER	30-002-02130165	--	1
7	M3_L5_Washer_Ni	22-242-30005311	7~8kgf-cm	1
6	PS3100_PRINTER_COVER_EJECTOR	30-002-09210165	--	1
5	PS3100-SPRING-FOR_EJECTOR	23-002-00001021	--	1
4	PS3100_EJECTOR HOLDER	20-029-03003165	--	1
3	T3_L8_R_Ni	22-122-30080011	7~8kgf-cm	1
2	CAPD24X_A_03 (2")	52-701-00020003	--	1/2
1	T3_L8_R_Ni	22-122-30080011	7~8kgf-cm	2
No.	Name	P/N No.	Torsion	Qt'y

**EXPLODED DIAGRAM FOR 3 INCH THERMAL PRINTER**  
**REMOVE/ INSTALL**

3" Printer Assembly

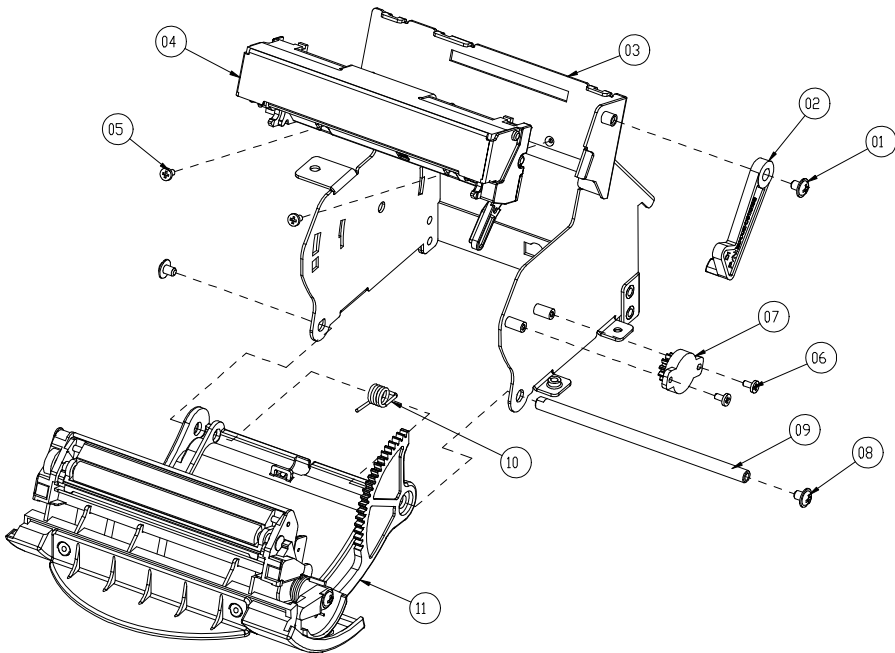

**Appendix A System Assembly**

---

11	Paper_cover_Assembly	SEE PAGE 18	--	1
10	PS3100-SPRING-1	23-002-00000701	--	1
9	Paper_cover_pin	20-004-10011165	---	1
8	M3_L5_Washer_Ni	22-242-30005311	7~8kgf-cm	2
7	ROTARY DAMPER	30-022-09110000	--	1
6	M2_L4_I_Ni	22-272-20004011	6~7kgf-cm	2
5	M2_L4_I_Ni	22-272-20004011	6~7kgf-cm	2
4	CAPD34X_A_01 (3')	52-701-00017003	--	1/2
3	PS3100_PRINTER_BOX3	20-040-03003165	--	1
2	Printer_add_arm	30-002-09110165	--	1
1	M3_L5_Washer_Ni	22-242-30005311	7~8kgf-cm	1
No.	Name	P/N No.	Torsion	Qt'y

3" Printer Cover Assembly

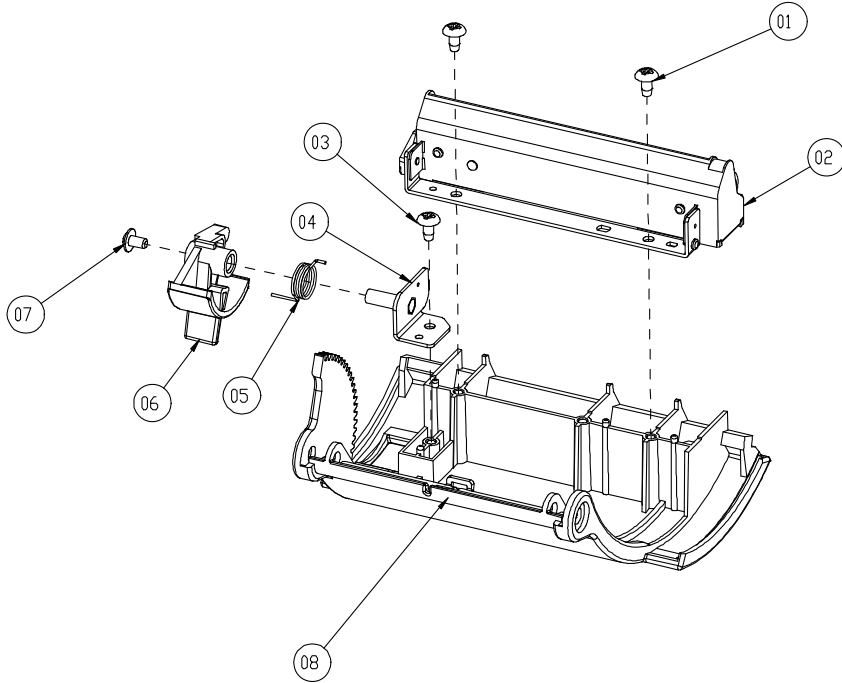

8	PS3100_PAPER_COVER	30-002-02130165	--	1
7	M3_L5_Washer_Ni	22-242-30005311	7~8kgf-cm	1
6	PRINTER_COVER_EJECTOR	30-002-09210165	--	1
5	PS3100-SPRING-FOR_EJECTOR	23-002-00001021	--	1
4	PS3100_EJECTOR_HOLDER	20-029-03003165	--	1
3	T3_L8_R_Ni	22-122-30080011	7~8kgf-cm	1
2	CAPD34X_A_01 (3")	52-701-00017003	--	1/2
1	T3_L8_R_Ni	22-122-30080011	7~8kgf-cm	2
No.	Name	P/N No.	Torsion	Qt'y



**EXPLODED DIAGRAM FOR MSR & FINGERPRINT MODULE REMOVE/ INSTALL**

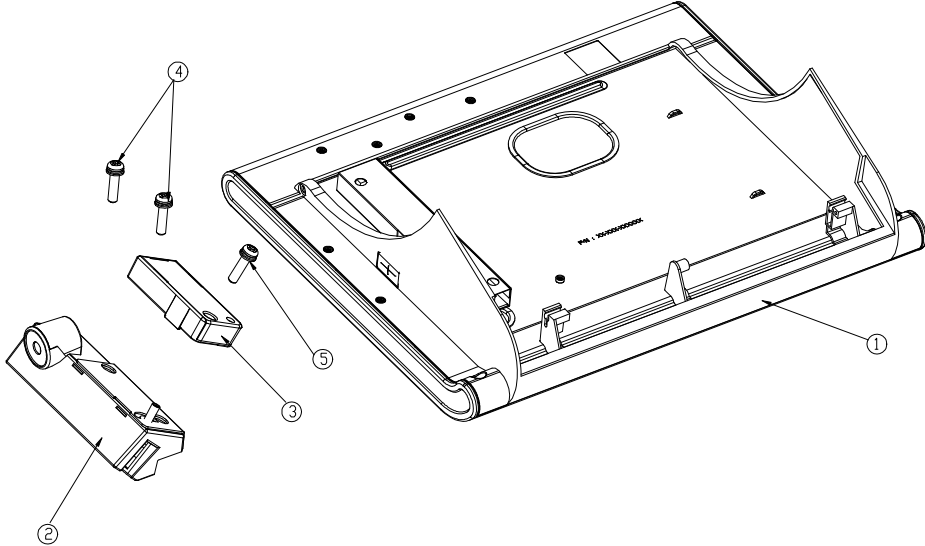

5	FRINGER PRINTER ASS'Y MODULE	22-222-30012811	6~7kgf-cm	1
4	MSR ASS'Y MODULE	22-275-30010011	6~7kgf-cm	1
3	FRINGER PRINTER ASS'Y MODULE		--	1
2	MSR ASS'Y MODULE		--	1
1	LCD ASS'Y MODULE			1
No.	Name	P/N No.	Torsion	Qt'y

**EXPLODED DIAGRAM FOR FINGERPRINT MODULE**

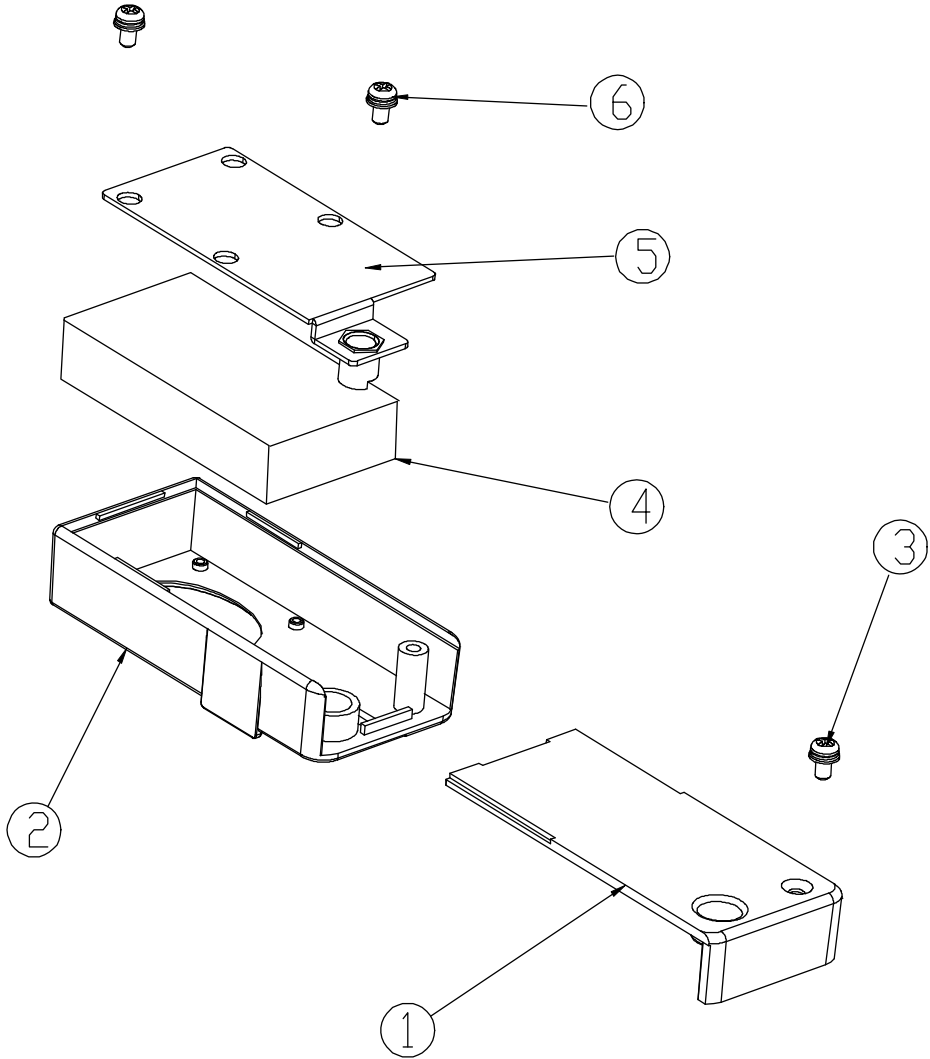

**Appendix A System Assembly**

---

6	T3 FLAT HEAD SCREW	22-712-30010011	5~6kgf-cm	2
5	FINGER PRINTER BKT	20-006-03002210	--	1
4	FINGER PRINTER		--	1
3	T3 FLAT HEAD SCREW	22-712-30010011	5~6kgf-cm	1
2	FINGER PRINTER TOP COVER	30-002-12120210	--	1
1	FINGER PRINTER BTM COVER	30-002-12220210		1
No.	Name	P/N No.	Torsion	Qt'y

**EXPLODED DIAGRAM FOR POS-3520 HARD DISK DRIVE  
REMOVE/ INSTALL**

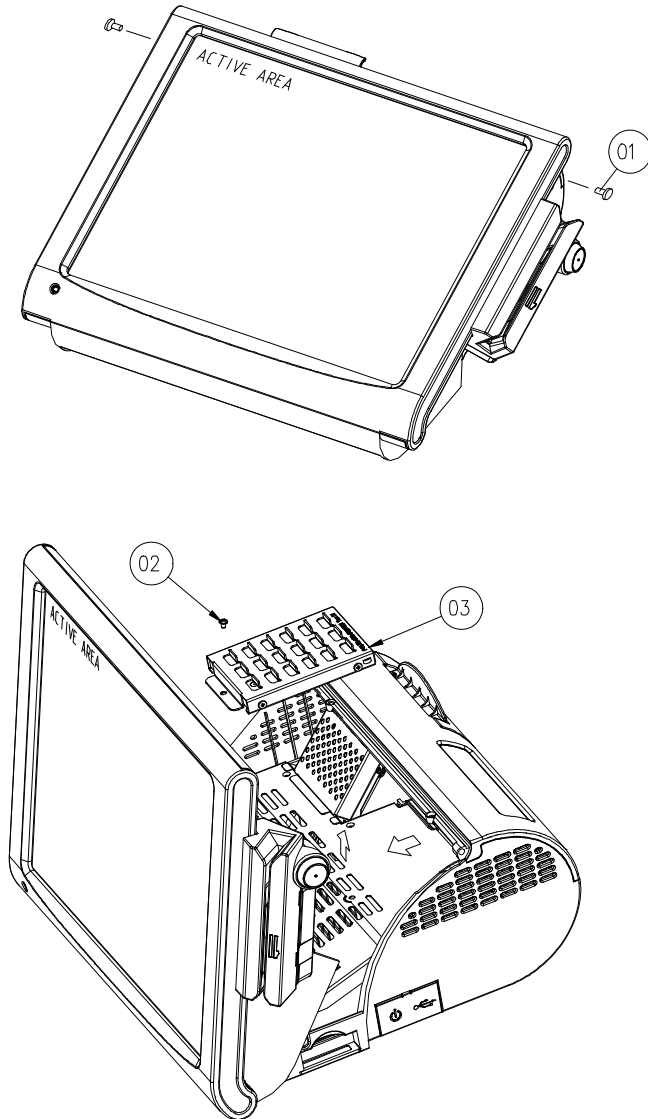

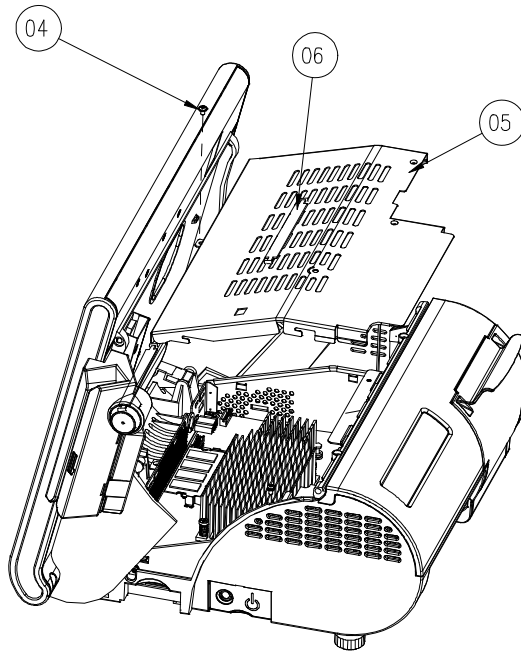

6	Inside_top_Assembly	30-080-04100000	--	1
5	Inside_top	20-040-03001165	--	1
4	M3_L5_Washer_Ni	22-242-30005311	7~8kgf-cm	1
3	HDD Assembly	SEE PAGE 20	--	1
2	M3_L5_Washer_Ni	22-242-30005311	7~8kgf-cm	1
1	M3_L4_I_B	22-272-30004318	6~7kgf-cm	2
No.	Name	P/N No.	Torsion	Qt'y

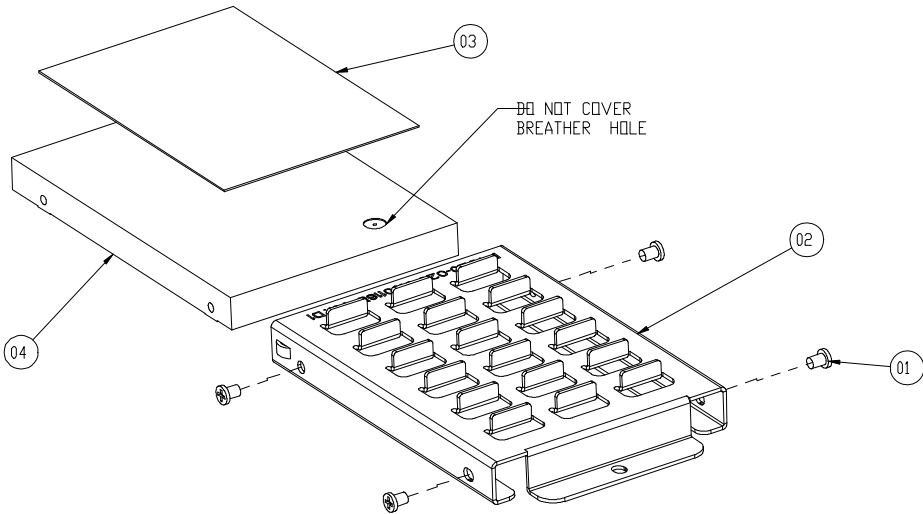

4	HDD	SEE ORDER	--	1
3	Thermal Pad	21-006-88560001	--	1
2	HDD_holder	20-029-01001165	--	1
1	M3_L4_I_B	22-272-30004318	6~7kgf-cm	4
No.	Name	P/N No.	Torsion	Qt'y

**EXPLODED DIAGRAM FOR POS-3520 LCD PANEL REMOVE/  
INSTALL**

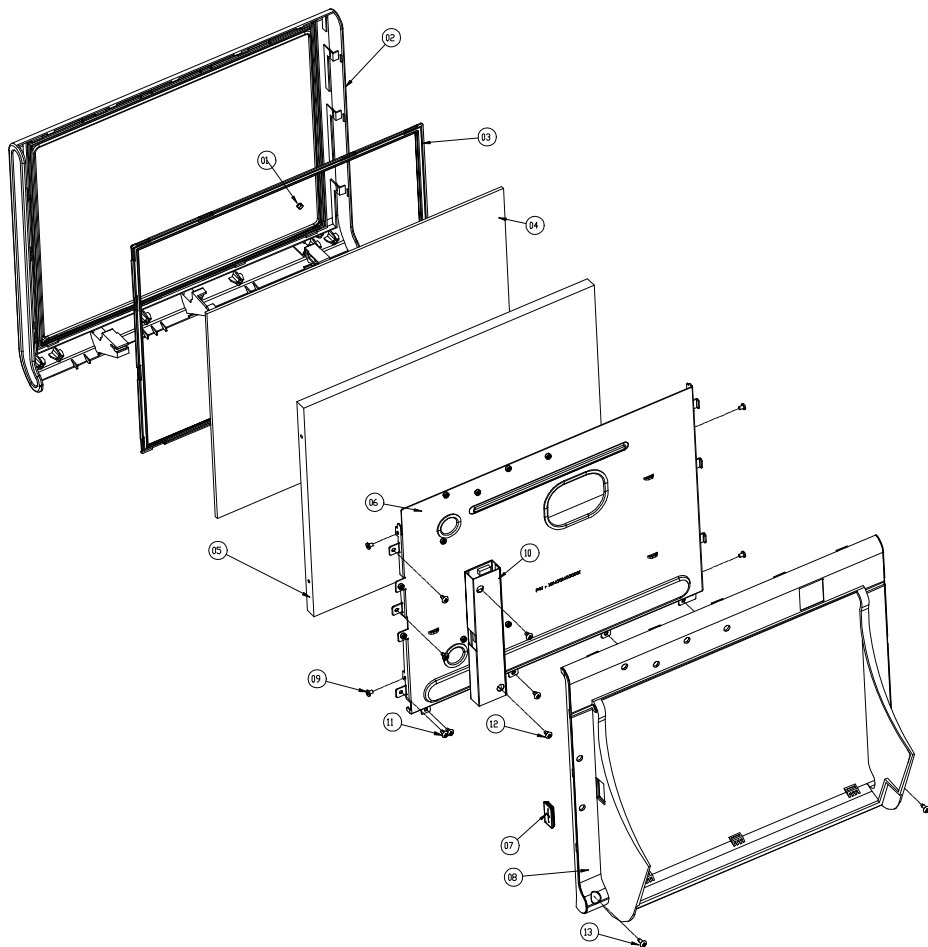

13	T3 L=5mm TAPING	22-132-30060011	3~3.5kgf-cm	1
12	M3_L5_Washer_Ni (INVERTER)	22-242-30005311	7~8kgf-cm	2
11	T3 L=5mm TAPING	22-132-30060011	3~3.5kgf-cm	7
10	INVERTER MYLAR		--	1
9	M3_L5_Washer_Ni		7~8kgf-cm	1
8	REAR COVER	30-002-12320210		1
7	RUBBER CAP	30-002-01100210	--	1
6	LCD METAL HOUSING	20-006-03001210	--	1
5	15" PANEL		--	1
4	TOUCH PANEL		--	1
3	TOUCH RUBBER		--	1
2	FRONT COVER	30-002-12620210	--	1
1	LED CAP	30-012-02100000	--	1
No.	Name	P/N No.	Torsion	Qt'y



**EXPLODED DIAGRAM FOR POS-3520 MINI-PCIE  
INSTALLATION**

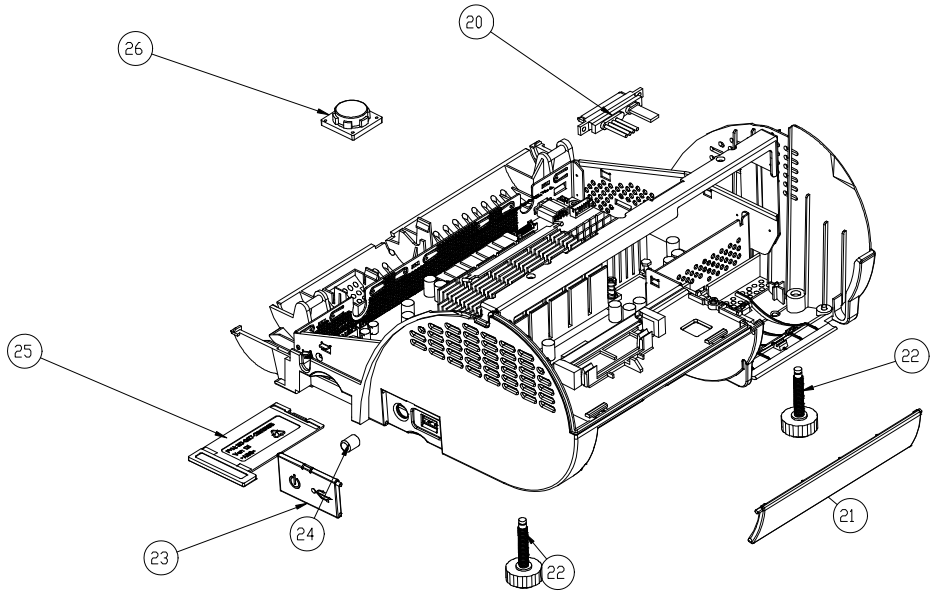

26	Speaker	13-400-00050018	--	1
25	MINI_PCIE_DOOR	30-007-28110165	--	1
24	Switch Cap	30-001-28100099	--	1
23	Side Door	30-007-28120165	--	1
22	Foot	22-289-60035007	--	2
21	I/O Cover	30-002-28110165	--	1
20	Sata HDD Cable	27-012-16504081	--	1
No.	Name	P/N No.	Torsion	Qt'y

**EXPLODED DIAGRAM FOR POS-3520 MOTHERBOARD**

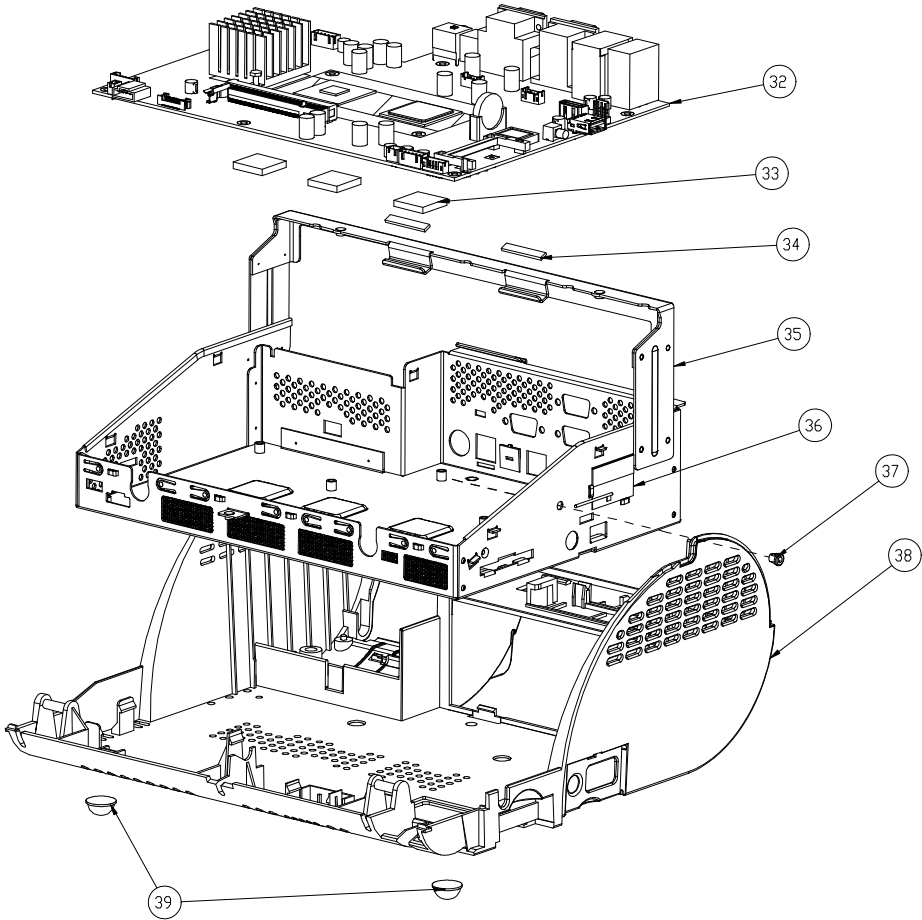

**Appendix A System Assembly**

---

39	Rubber Foot	30-004-01500000	--	1
38	PS3100 BOT CASE	30-002-12110165	--	1
37	SB-0305	30-026-04100008	--	1
36	WIRELESS_ANTENNA	27-029-00003072	--	1
35	inside box	20-040-03002165		1
34	EMI SPONGE	5x12x26 mm	--	2
33	Thermal Pad	21-006-82020002	--	3
32	Prox3100	Prox-3100	--	1
No.	Name	P/N No.	Torsion	Qt'y

**EXPLODED DIAGRAM FOR POS-3520 MSR MODULE**

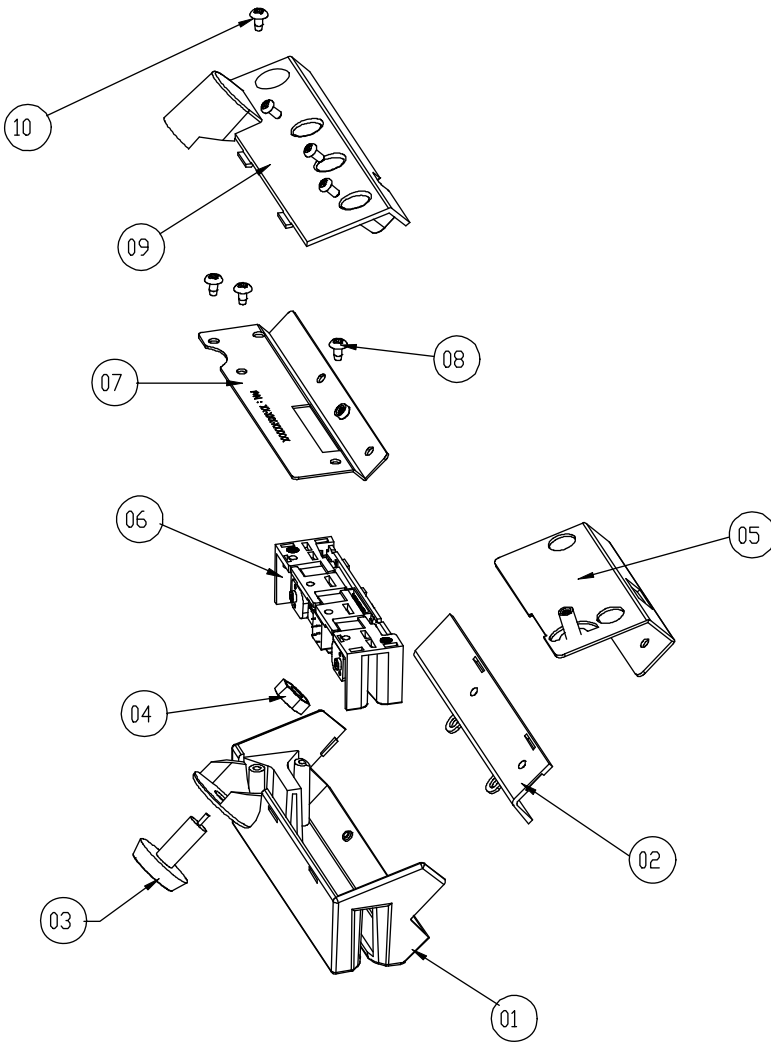

10	M3 TAPPING SCREW	20-006-03003210	4~5kgf-cm	2
9	MSR BTM COVER	30-002-12420210		1
8	M6_L6_F_B	22-232-30060211	6~7kgf-cm	2
7	MSR FIX BRACKET	20-006-03003210	--	1
6	MSR MODULE			1
5	MSR BRACKET	20-006-03061210	--	1
4	I BUTTON NUT		--	1
3	I BUTTON		--	1
2	MSR TOP COVER SIDE	30-002-12520210	--	1
1	MSR TOP COVER	30-014-12120210		1
No.	Name	P/N No.	Torsion	Qt'y

**EXPLODED DIAGRAM FOR POS-3520 MSR & LCD ASSEMBLY**

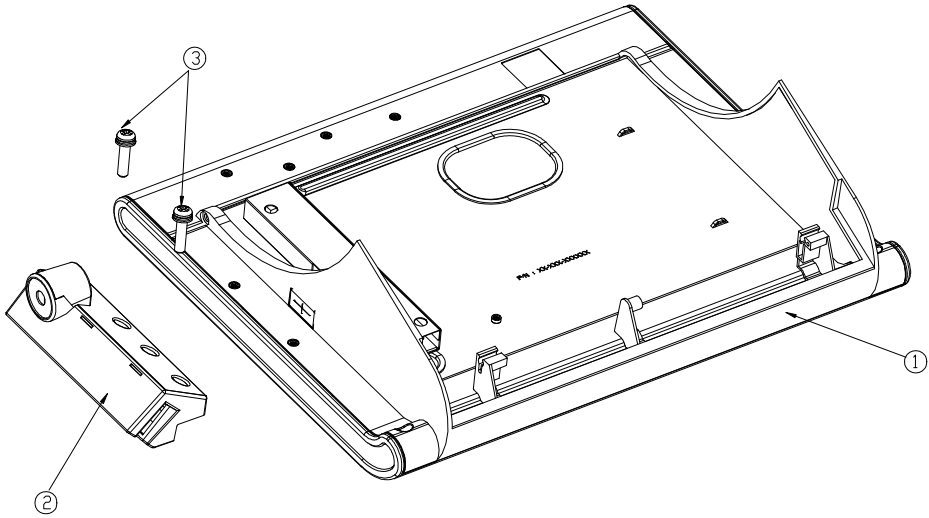

3	M3 SCREW	22-275-30010011	6~7kgf-cm	2
2	MSR ASS'Y MODULE	30-002-12520210	--	1
1	LCD ASS'Y MODULE	30-014-12120210		1
No.	Name	P/N No.	Torsion	Qt'y

**EXPLODED DIAGRAM FOR POS-3520 PRINTER ASSEMBLY**

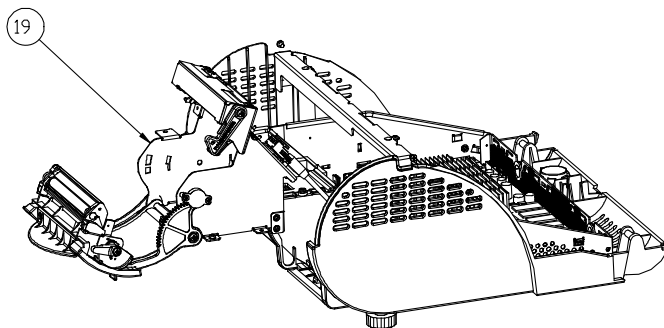
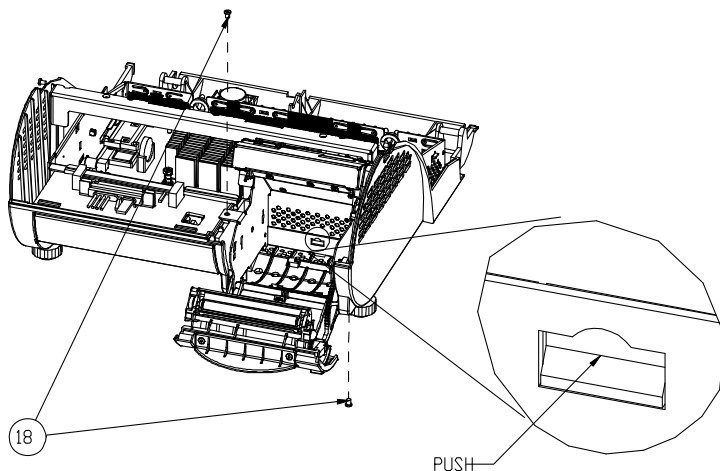

19	Printer Assembly	SEE PAGE 16,17	--	1
18	M3_L4_I_B	22-272-30004318	6~7kgf-cm	2
No.	Name	P/N No.	Torsion	Qt'y

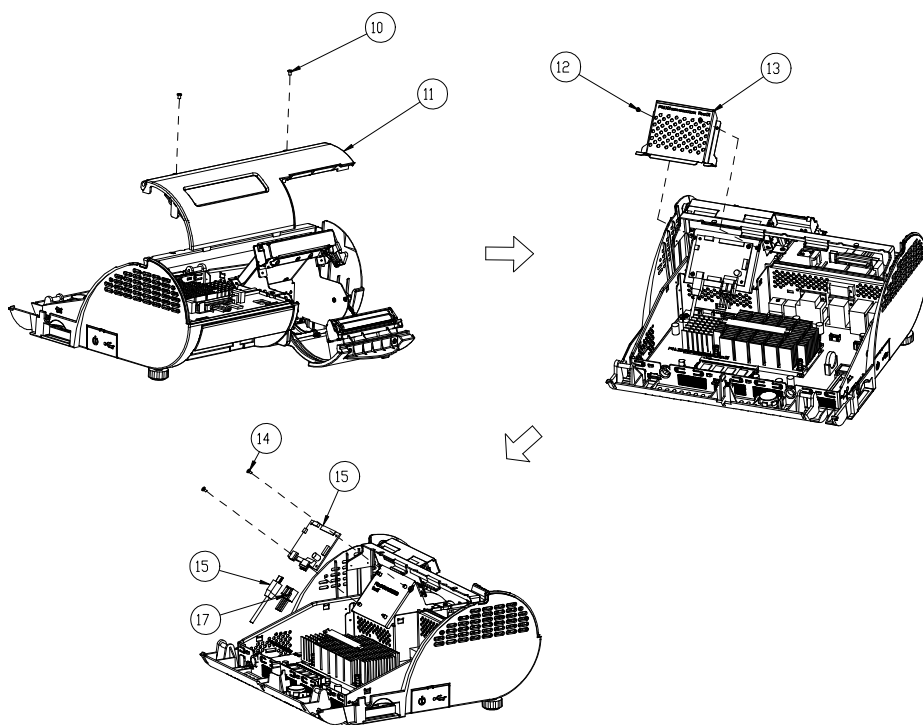

17	Printer Power Cable	27-012-16502071	--	1
16	Printer USB cable	27-006-16503111	--	1
15	Printer PCB	52-701-00237003	--	1
14	M2_L4_I_Ni	22-272-20004011	5~6kgf-cm	2
13	PCB_COVER	20-004-03001165	--	1
12	M2_5_L4_R_Ni	22-232-25004011	6~7kgf-cm	2
11	VFD Assembly	SEE PAGE 15	--	1
10	M3_L4_I_B	22-272-30004318	6~7kgf-cm	2
No.	Name	P/N No.	Torsion	Qty



**EXPLODED DIAGRAM FOR POS-3520 TOP COVER ASSEMBLY**

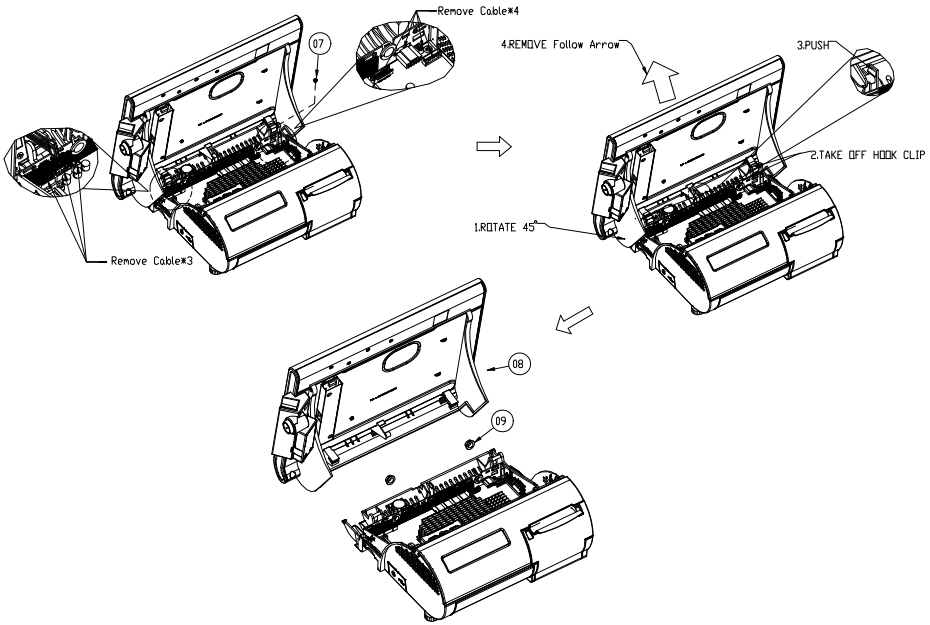

9	Open Closed Bushing	30-026-04300000	--	2
8	TOP Assembly	SEE PAGE 8,9,10	--	1
7	M3_L5_Washer_Ni	22-242-30005311	6~7kgf-cm	1
No.	Name	P/N No.	Torsion	Qt'y

**EXPLODED DIAGRAM FOR VFD MODULE ASSEMBLY**

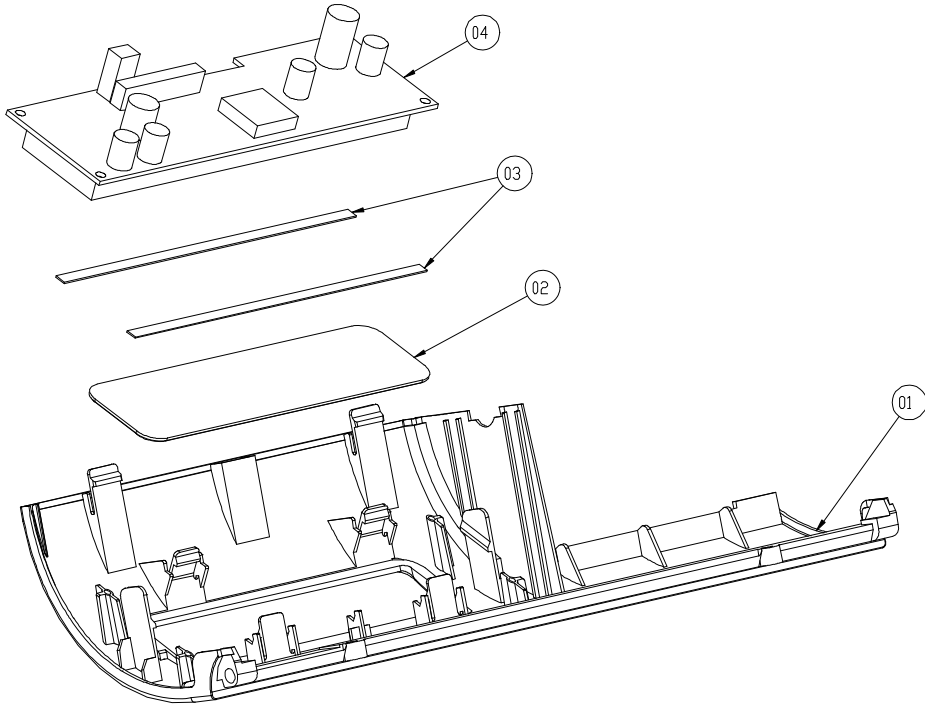

4	VFD_MODULE	52-901-17001703	--	1
3	PYLON	30-013-24700000	--	2
2	VFD_WINDOWS	30-002-02230165	--	1
1	VFD_COVER(Blue)	30-002-28410165	--	1
	VFD_COVER(Red)	30-002-28610165	--	1
No.	Name	P/N No.	Torsion	Qt'y

# ***TECHNICAL SUMMARY***

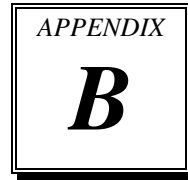

This section will give you a brief introduction of the maps.

Section includes:

- Block Diagram
- Interrupt Map
- DMA Channels Map
- I / O Map
- Watchdog Timer Configuration
- Flash BIOS Update

BLOCK DIAGRAM

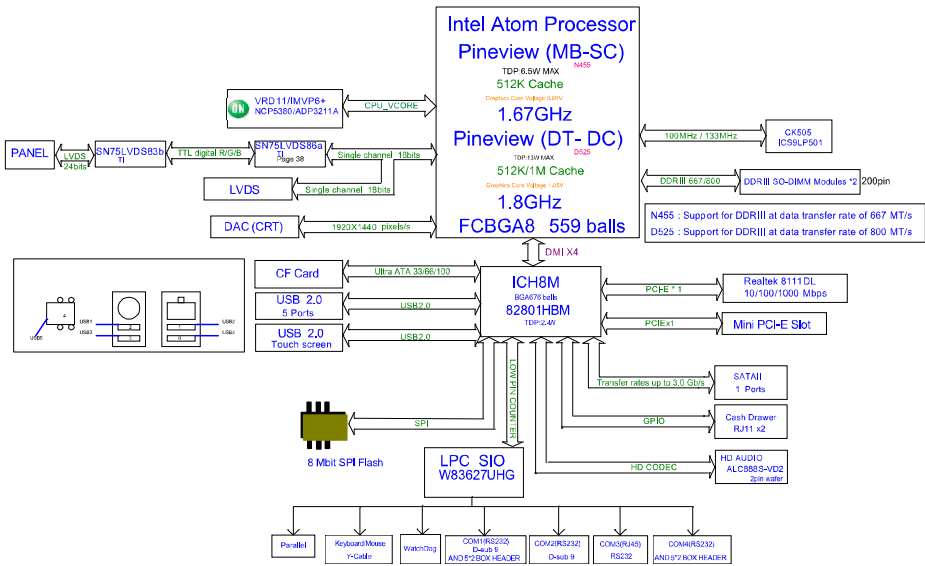

## INTERRUPT MAP

IRQ	ASSIGNMENT
0	System Timer
1	Standard 101/102-Key or Microsoft Natural PS/2 Keyboard
3	Communications Port (COM2)
4	Communications Port (COM1)
5	Intel(R) ICH8 Family SMBus Controller - 283E
8	System CMOS/real time clock
9	Microsoft ACPI-Compliant System
10	Communications Port (COM4)
11	Communications Port (COM3)
12	Microsoft PS/2 Mouse
13	Numeric data processor
14	Primary IDE Channel
16	Intel(R) Graphics Media Accelerator 3150
16	Intel(R) ICH8 Family USB Universal Host Controller - 2834
17	Realtek PCIe GBE Family Controller
18	Intel(R) ICH8 Family USB2 Enhanced Host Controller - 283A
18	Intel(R) ICH8 Family USB Universal Host Controller - 2832
18	Intel(R) ICH8M 3 port Serial ATA Storage Controller - 2828
19	Intel(R) ICH8 Family USB Universal Host Controller - 2831
21	Intel(R) ICH8 Family USB Universal Host Controller - 2835
21	Microsoft UAA Bus Driver for High Definition Audio
22	Intel(R) ICH8 Family PCI Express Root Port 1 - 283F
23	Intel(R) ICH8 Family PCI Express Root Port 6 - 2849
23	Intel(R) ICH8 Family USB Universal Host Controller - 2830
23	Intel(R) ICH8 Family USB2 Enhanced Host Controller - 2836

## DMA CHANNELS MAP

DMA Channel	Assignment
4	Direct memory access controller

## I/O MAP

I/O MAP	ASSIGNMENT
0x00000000-0x00000CF7	PCI bus
0x00000000-0x00000CF7	Direct memory access controller
0x00000010-0x0000001F	Motherboard resources
0x00000020-0x00000021	Programmable interrupt controller
0x00000022-0x0000003F	Motherboard resources
0x00000040-0x00000043	System timer
0x00000044-0x0000005F	Motherboard resources
0x00000060-0x00000060	Standard 101/102-Key or Microsoft Natural PS/2 Keyboard
0x00000061-0x00000061	System speaker
0x00000062-0x00000063	Motherboard resources
0x00000064-0x00000064	Standard 101/102-Key or Microsoft Natural PS/2 Keyboard
0x00000065-0x0000006F	Motherboard resources
0x00000070-0x00000071	System CMOS/real time clock
0x00000072-0x0000007F	Motherboard resources
0x00000080-0x00000080	Motherboard resources
0x00000081-0x00000083	Direct memory access controller
0x00000084-0x00000086	Motherboard resources
0x00000087-0x00000087	Direct memory access controller
0x00000088-0x00000088	Motherboard resources
0x00000089-0x0000008B	Direct memory access controller
0x0000008C-0x0000008E	Motherboard resources
0x0000008F-0x0000008F	Direct memory access controller
0x00000090-0x0000009F	Motherboard resources
0x000000A0-0x000000A1	Programmable interrupt controller
0x000000A2-0x000000BF	Motherboard resources
0x000000C0-0x000000DF	Direct memory access controller

<b>I/O MAP</b>	<b>ASSIGNMENT</b>
0x000000E0-0x000000EF	Motherboard resources
0x000000F0-0x000000FF	Numeric data processor
0x000001F0-0x000001F7	Primary IDE Channel
0x00000274-0x00000277	ISAPNP Read Data Port
0x00000279-0x00000279	ISAPNP Read Data Port
0x000002E8-0x000002EF	Communications Port (COM4)
0x000002F8-0x000002FF	Communications Port (COM2)
0x00000378-0x0000037F	Printer Port (LPT1)
0x000003B0-0x000003BB	Intel(R) Graphics Media Accelerator 3150
0x000003C0-0x000003DF	Intel(R) Graphics Media Accelerator 3150
0x000003E8-0x000003EF	Communications Port (COM3)
0x000003F6-0x000003F6	Primary IDE Channel
0x000003F8-0x000003FF	Communications Port (COM1)
0x00000400-0x0000041F	Intel(R) ICH8 Family SMBus Controller - 283E
0x000004D0-0x000004D1	Motherboard resources
0x00000500-0x0000053F	Motherboard resources
0x00000800-0x0000087F	Motherboard resources
0x00000A00-0x00000A0F	Motherboard resources
0x00000A00-0x00000A0F	Motherboard resources
0x00000D00-0x0000FFFF	PCI bus
0x0000C080-0x0000C087	Intel(R) Graphics Media Accelerator 3150
0x0000C400-0x0000C41F	Intel(R) ICH8 Family USB Universal Host Controller - 2835
0x0000C480-0x0000C49F	Intel(R) ICH8 Family USB Universal Host Controller - 2834
0x0000C800-0x0000C81F	Intel(R) ICH8 Family USB Universal Host Controller - 2832
0x0000C880-0x0000C89F	Intel(R) ICH8 Family USB Universal Host Controller - 2831
0x0000CC00-0x0000CC1F	Intel(R) ICH8 Family USB Universal Host Controller - 2830
0x0000D080-0x0000D08F	Intel(R) ICH8M 3 port Serial ATA Storage Controller - 2828
0x0000D400-0x0000D40F	Intel(R) ICH8M 3 port Serial ATA Storage Controller - 2828
0x0000D480-0x0000D483	Intel(R) ICH8M 3 port Serial ATA Storage Controller - 2828
0x0000D800-0x0000D807	Intel(R) ICH8M 3 port Serial ATA Storage Controller - 2828
0x0000D880-0x0000D883	Intel(R) ICH8M 3 port Serial ATA Storage Controller - 2828

<b>I/O MAP</b>	<b>ASSIGNMENT</b>
0x0000DC00-0x0000DC07	Intel(R) ICH8M 3 port Serial ATA Storage Controller - 2828
0x0000E000-0x0000EFFF	Intel(R) ICH8 Family PCI Express Root Port 6 - 2849
0x0000E800-0x0000E8FF	Realtek PCIe GBE Family Controller
0x0000FFA0-0x0000FFAF	Intel(R) ICH8M Ultra ATA Storage Controllers - 2850



## **WATCHDOG TIMER CONFIGURATION**

Watchdog timer can be configured via I/O port address 2E (hex) and 2F (hex). 2E (hex) is the address port. 2F (hex) is the data port. User can assign the target offset by writing value into address port 2E (hex) and then write/read data to/from the target offset by data port 2F (hex).

### **Configuration Sequence**

Please follow the following steps to program [W83627UHG](#) configuration registers.

- (1) Enter the extended function mode.
- (2) Configure the configuration registers.
- (3) Exit the extended function mode.

#### **(1) Enter the extended function mode**

To place [W83627UHG](#) into the Extended Function Mode, two successive writes of 0x87 must be applied to Extended Function Enable Registers (EFERs, i.e. 2Eh or 4Eh).

#### **(2) Configure the configuration registers**

User must select to the desired Logical Device number and activates the desired Logical Devices through Extended Function Index Register (EFIR) and Extended Function Data Register (EFDR). The EFIR is located at the same address as the EFER, and the EFDR is located at address (EFIR+1). First, write the Logical Device Number (i.e. 0x07) to the EFIR and then write the number of the desired Logical Device to the EFDR. If accessing the Chip (Global) Control Registers, this step is not required. Secondly, write the address of the desired configuration register within the Logical Device to the EFIR and then write (or read) the desired configuration register through the EFDR.

#### **(3) Exit the extended function mode**

To exit the Extended Function Mode, writing 0xAA to the EFER is required. Once SuperIO exits the Extended Function Mode, it goes back to the normal running mode.

### Code example for watch dog timer

Enable watchdog timer and set timeout interval to 30 seconds.

```
;----- Enter to extended function mode -----
mov    dx,    2Eh
mov    al,    87h
out    dx,    al
out    dx,    al
;----- Select Logical Device 8 of watchdog timer -----
mov    al,    07h
out    dx,    al
inc    dx
mov    al,    08h
out    dx,    al
;----- Logic device activation for watch dog timer -----
dec    dx
mov    al,    030h
out    dx,    al
inc    dx
mov    al,    01h
out    dx,    al
;----- Set second as counting unit -----
dec    dx
mov    al,    0F5h
out    dx,    al
inc    dx
in     al,    dx
and    al,    not 08h
out    dx,    al
;----- Set timeout interval as 30seconds and start counting -----
dec    dx
mov    al,    0F6h
out    dx,    al
inc    dx
mov    al,    30
out    dx,    al
;----- Exit the extended function mode -----
dec    dx
mov    al,    0AAh
out    dx,    al
```

## FLASH BIOS UPDATE

### A. Before System BIOS update

1. Prepare a bootable media (ex. USB storage device) which can boot system to DOS prompt.
2. Download and save the BIOS ROM (ex. [35200T04.rom](#)) file to the bootable device.
3. Copy AMI flash utility – AFUDOS.exe (v4.38) into bootable device.

```
C:\AFUDOS>dir

Volume in drive C is JASON
Volume Serial Number is 58AA-C5FF
Directory of C:\AFUDOS

.                <DIR>                04-28-11  10:23a
..               <DIR>                04-28-11  10:23a
AFUDOS           EXE             154,416   01-25-11  4:05p
AFUDOS           TXT              13,066   01-25-11  4:05p
35200T04         ROM           1,048,576 04-29-11  9:39a
3 file(s)                1,216,058 bytes
2 dir(s)                 305,991,680 bytes free

C:\AFUDOS>_
```

4. Make sure the target system can first boot to the bootable device.
  - (1) Connect the bootable USB device.
  - (2) Turn on the system and press <Del> key during BIOS POST procedure.
  - (3) System will go into the BIOS setup menu.
  - (4) Select [Boot] menu.
  - (5) Select [Boot Devices Priority] sub-menu, set the USB bootable device to be the 1st boot device.
  - (6) Pressing <F10> key to save configuration and exit the BIOS setup menu.



### B. AFUDOS command for system BIOS update

AFUDOS.exe is the AMI firmware update utility, the command line is shown as below:

**AFUDOS <ROM File Name> [option1] [option2]....**

User can type “AFUDOS/?” to see all the definition of each control options. The recommend option for BIOS ROM update include following parameters:

- /P:** Program main BIOS image.
- /B:** Program Boot Block.
- /N:** Program NVRAM.
- /C:** Destroy CMOS checksum
- /X:** Don't check ROM ID.

### C. BIOS update procedure

1. Use the bootable USB storage to boot up system into the DOS command prompt.
2. Type "**AFUDOS 3520xxxx.ROM /P /B /N /C /X**" and press enter to start the flash procedure.  
(Note that **xxxx** means the BIOS revision part, ex. 0P01...)
3. During the update procedure, you will see the BIOS update process status and its percentage. Beware! Do not turn off system power or reset your computer if the whole procedure are not complete yet, or it may crash the BIOS ROM and make system unable to boot up next time.
4. After BIOS update procedures complete, the messages should be like the figure shown below.

```
C:\AFUDOS>afudos 35200t04.rom /P /B /N /C /X
+-----+
|                AMI Firmware Update Utility  v4.38                |
|                Copyright (C)2010 American Megatrends Inc. All Rights Reserved. |
+-----+
- Bootblock checksum .... ok
- Module checksums ..... ok
- Erasing flash ..... done
- Writing flash ..... done
- Verifying flash ..... done
- Erasing NURAM ..... done
- Writing NURAM ..... done
- Verifying NURAM ..... done
- Erasing Bootblock .... done
- Writing Bootblock .... done
- Verifying Bootblock ... done
- CMOS checksum destroyed
- Program ended normally.

C:\AFUDOS>_
```

5. User can restart the system and boot up with new BIOS now.